

## Nordik 48TL Refractory Panel Installation

For Part#: NK48TL-CB900, NK48TL-BB900, NK48TL-HB900, NK48TL-L900

**WARNING:** This product can expose you to chemicals including Ethylbenzene which is (are) known to the State of California to cause cancer, birth defects, or other reproductive harm. For more information, visit [www.P65Warnings.ca.gov](http://www.P65Warnings.ca.gov)

- Included Parts: (2) Side Refractory Panels, (1) Rear Refractory Panel, (4) panel clips

Note: The panel clips are shipped flat. Separate clips and bend the metal fingers at a 90° angle. The metal fingers can be trimmed according to your installation. Ensure there is enough material to hold the panel.

### Installation:

1. Remove the safety screen barrier, glass assembly, log set (if installed).
2. Remove the (2) screws securing the front ember bed media tray. Remove the (2) screws securing the front light kit. See Figure 1.
3. Next remove the left, center, and right burner assemblies by removing the (3) sheet metal screws that secures each burner assembly to the bottom burner and the floor of the control board. See Figure 2.
4. Install the rear refractory panel and secure the panel with two of the provided refractory clips. Loosen the (2) screws in the baffle to install the clips and then tighten the screws to secure the clips. See Figure 3, 4, and 5. Figure 5 show the panel clips unpainted as they are easier to see for instructions.
5. Install each side refractory panel and secure each panel with a refractory clip. One each side you will loosen the screw in the front corner of the firebox to install the clip and then righten the screw to secure the clip See Figure 3, 4, and 6. Figure 6 show the panel clip unpainted as they are easier to see for instructions.
6. Reinstall all previously removed components.

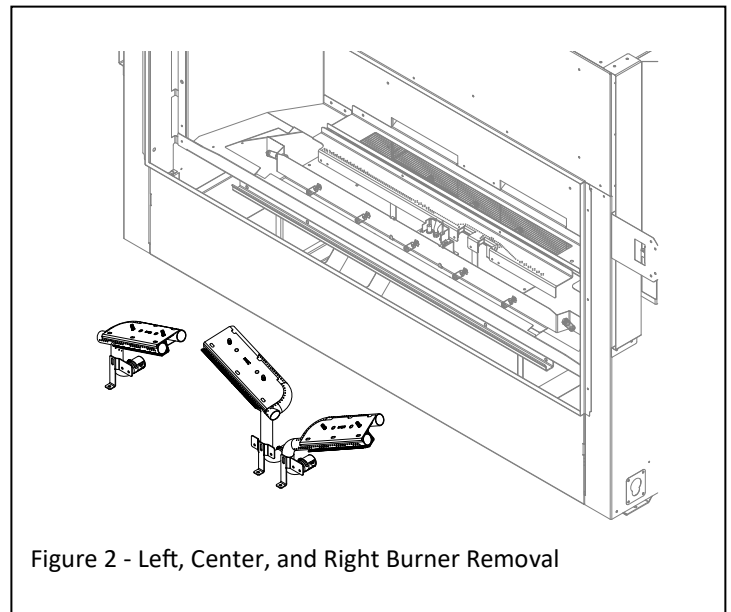
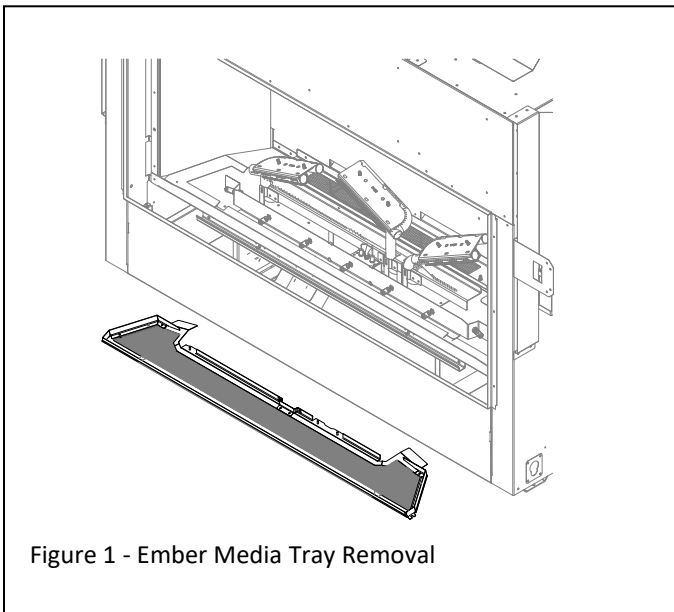



Figure 3 - Panel Identification

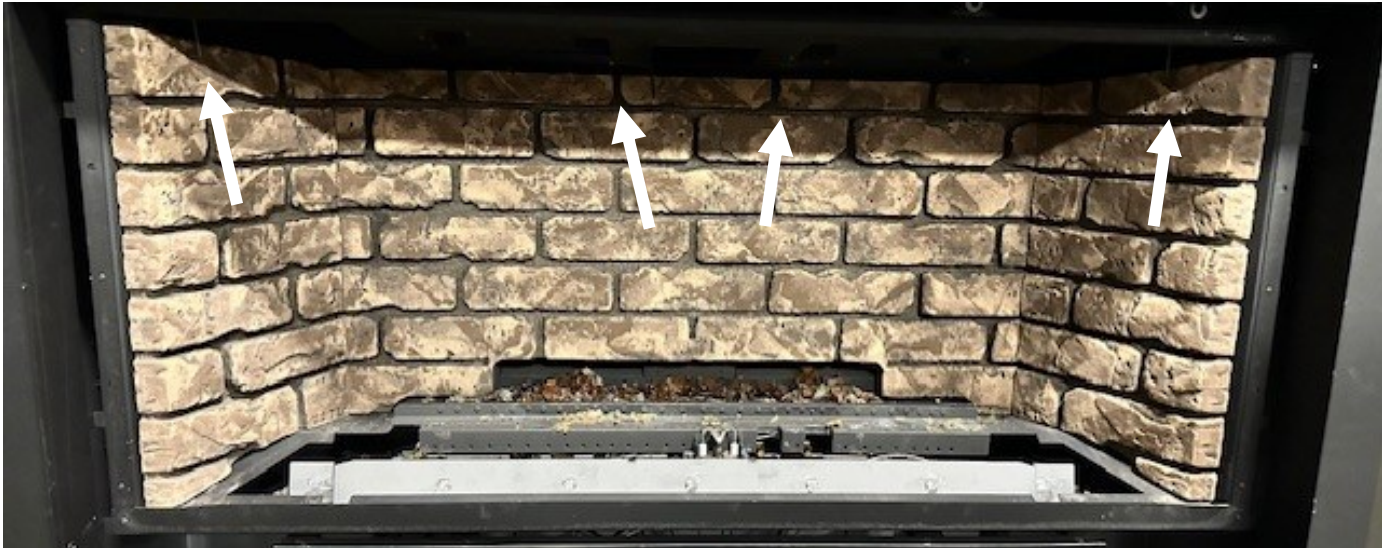

Figure 4 - Panel Clip Location



Figure 5 - Rear Panel Clip Location

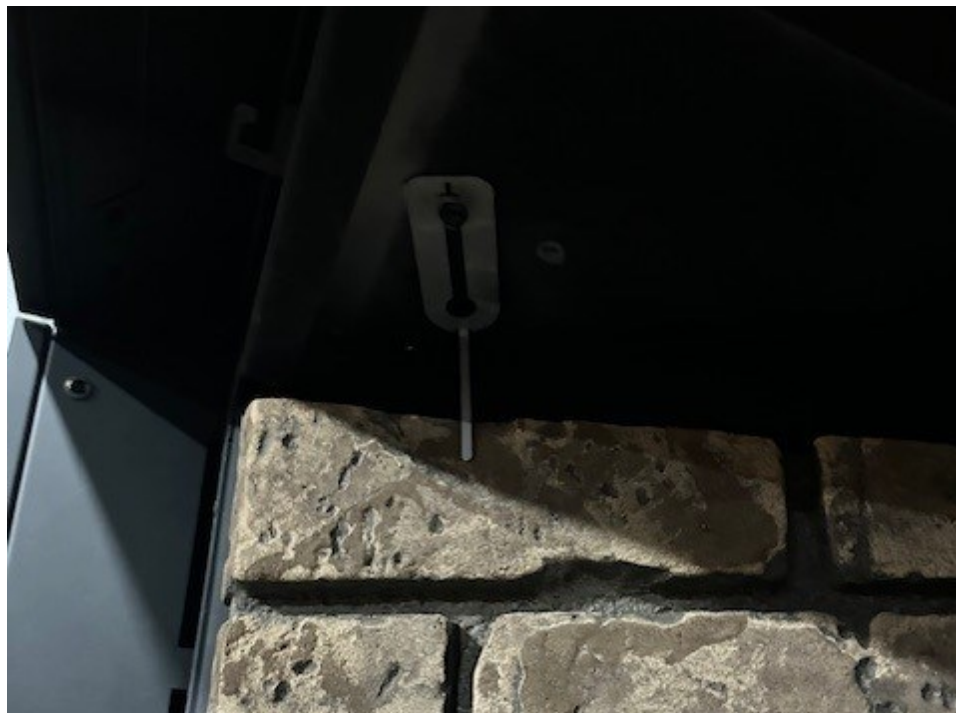

Figure 6 - Side Panel Clip Location