

#NK48-B501 BIRCH LOG SET

For use with model #NDK-48-DV

WARNING: This product can expose you to chemicals including ceramic fiber and/or silica dust which is (are) known to the State of California to cause cancer, birth defects, or other reproductive harm. For more information, visit www.P65Warnings.ca.gov

NOTE: Log numbers are located on the bottom or side of each log. Refer to the following instructions and illustration for proper placement. Your components may look different than the ones shown.

CAUTION: Do not place logs directly over burner port holes. Improper log placement may affect flame appearance and may cause excessive soot to build upon the glass.

- If converting to propane, complete the conversion before installing the log set. Follow the conversion instructions included with the kit.
 - If installing a panel set, complete installation of panel set before log installation
 - Install all light bulbs into the front ember bed light kit before log installation.
1. Remove valance from fireplace. Remove and retain (4) screws from the log rack/ember media tray. See Figure 1.
 2. Place log #N48-B1 on the far left and log #N48-B2 on the far right. There are corresponding pins on floor that hold these in position (pins not shown). Logs must lie flat on media tray. Failure to do so will negatively affect the flame
 3. Make sure the light bulbs for the rear light kit are installed. Install the crushed media on the rear light kit. Place log #N48-B5 and log #N48-B6 on top of the crushed glass as shown.
 4. Install klinkers on rear burner as shown. Do not cover burner ports.

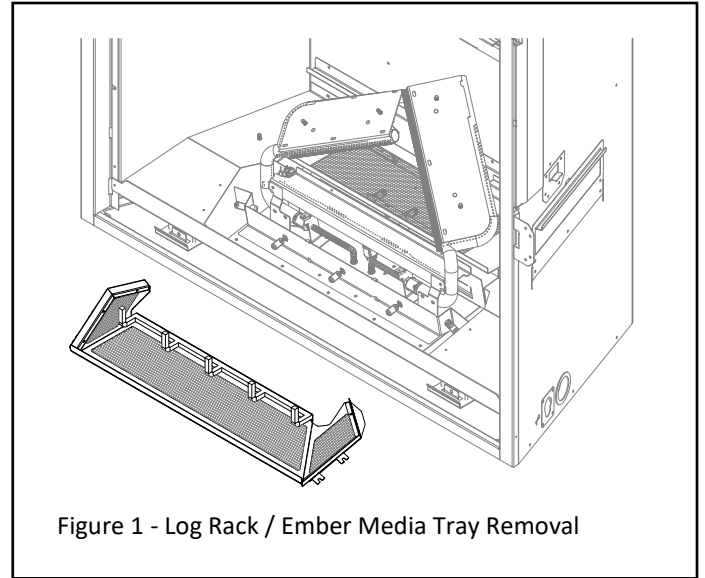

Figure 1 - Log Rack / Ember Media Tray Removal

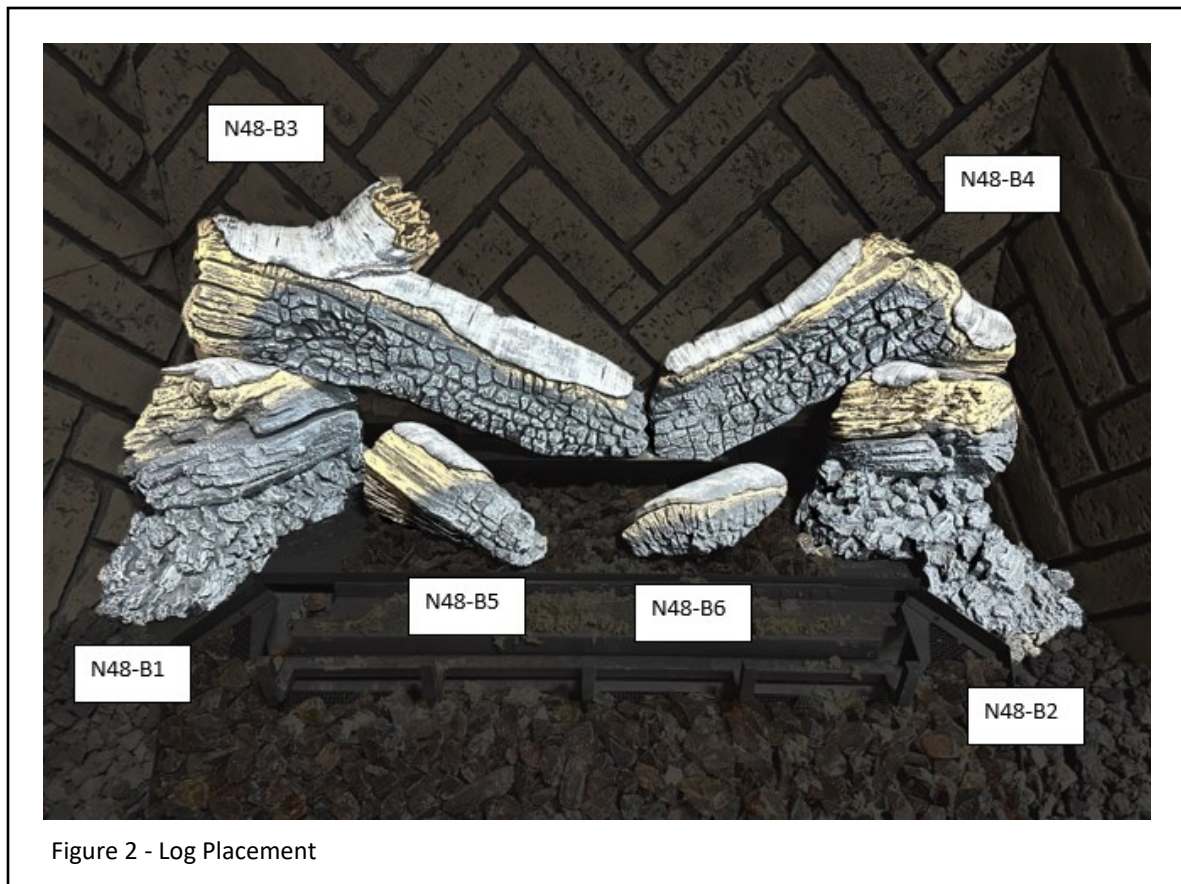
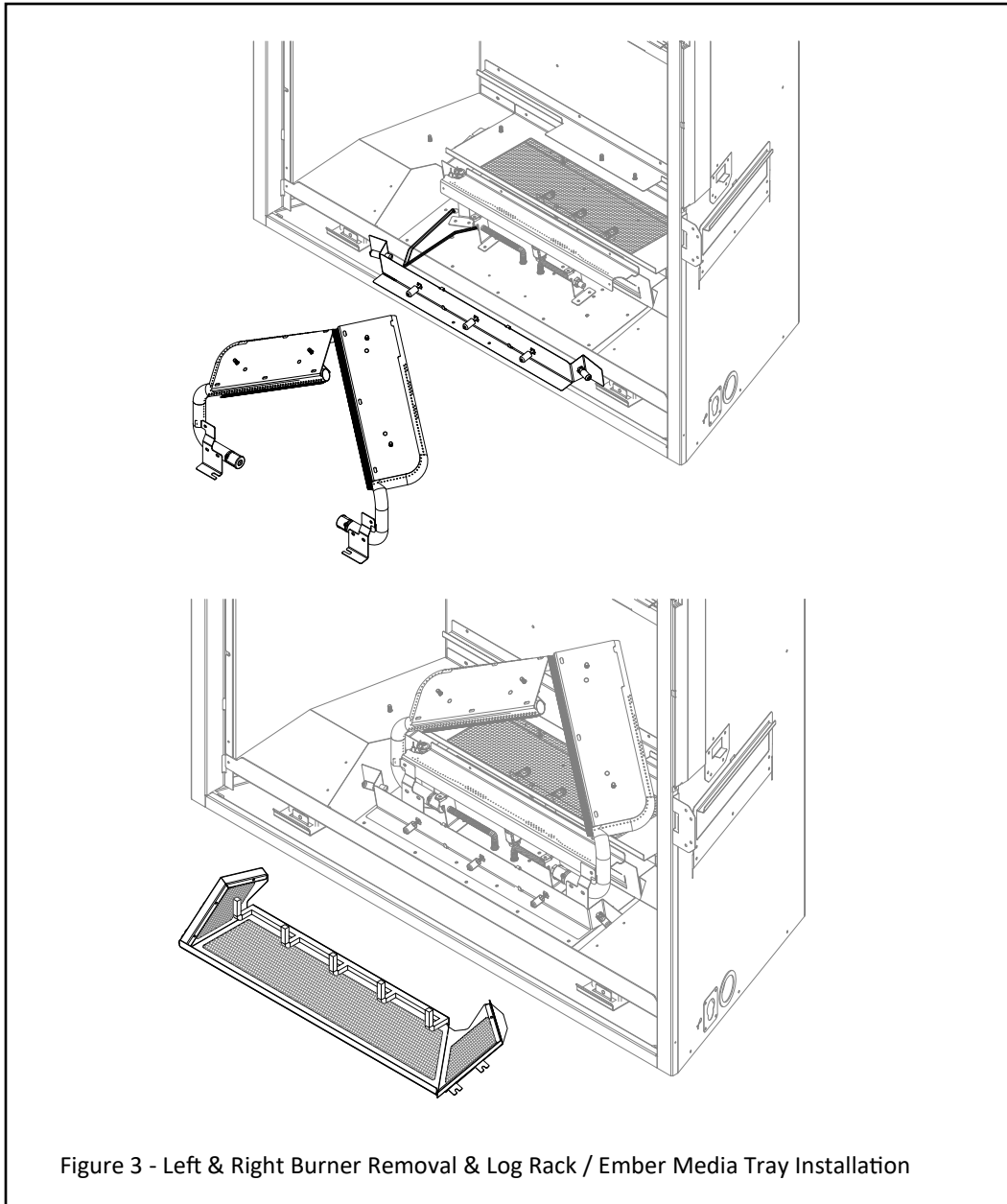

Figure 2 - Log Placement

#NK48-B501 BIRCH LOG SET

For use with model #NDK-48-DV

5. Install log #N48-B3. Position log #N48-B3 so it sits on top of log #N48-B1 and the metal platform above the air chute opening as shown. Secure the log on the studs.
6. Install log #N48-B4. Position log #N48-B4 so it sits on top of log #N48-B2 and the metal platform above the air chute opening as shown. Secure the log on the studs.
7. Install the left and right burner assemblies. Slide each burner over the burner orifice. Tighten the flange nut on the bracket at the bottom of the burner tube. Secure each burner with (1) sheet metal screw through the tab into the rear burner.
8. Ensure light bulbs are installed in the front light kit. Install the log rack / ember bed media tray. Secure with (4) sheet metal screws. Install the crushed glass on top of the media tray. Install the lava rock on the solid media section to the left and right of the media tray.
9. Install the logs #N48-B7 and #N48-B8 on the left and right burner assemblies via the PEM studs.
10. Install logs #N48-B9 thru #N48-B13.
11. Use a stiff or steel bristle brush to distribute rockwool embers onto the burners and logs. Reinstall valance and safety screen on fireplace.



#NK48-B501 BIRCH LOG SET

For use with model #NDK-48-DV

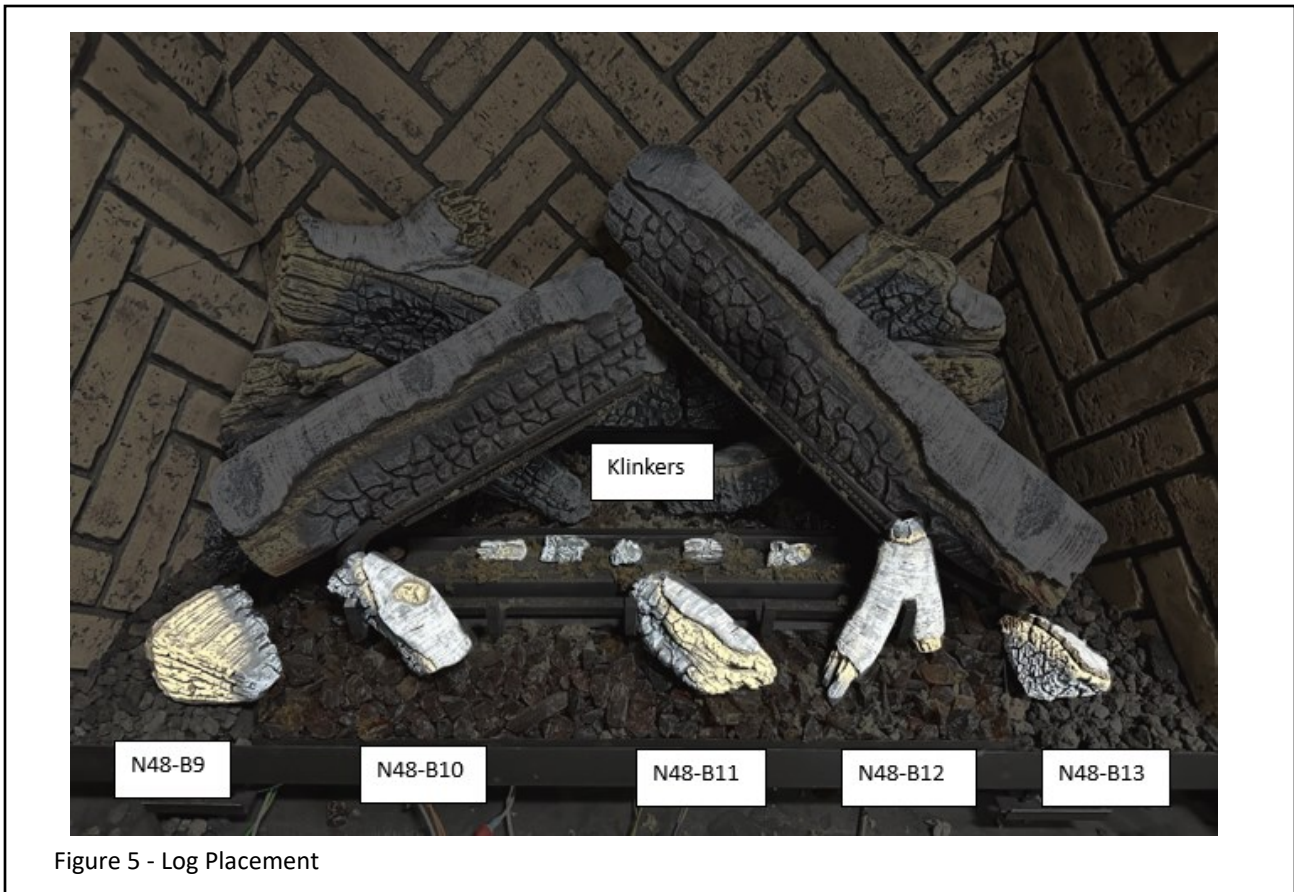

#NK48-B501 BIRCH LOG SET

For use with model #NDK-48-DV

Rockwool Installation

- After installation of the log set you can apply rockwool across logs N48-B7, N48-B8, left & right burner screen and rear burner.
- Use a small brush to brush the rockwool across the locations referenced above. Rockwool will provide a glow as the fireplace operates.
- DO NOT place the rockwool in excessively large pieces that would block large sections of burner ports. Excessive use of rockwool that blocks burner porting can create undesired flame characteristics and/or a possible delayed ignition.
- Make sure no rockwool is blocking the pilot flame or around the pilot assembly.

Lightly brush rock wool embers
into the area between the
screen and the burner tube

