

# INSTALLATION AND OPERATION MANUAL

## Nordik 60 TL

**Model #NDK-60-TL**  
Direct Vent Gas Fireplace

Evolution of Fire™

with the EVO Elevated Burner™ Design

English and French installation manuals are available through your local dealer or website. Visit our website [www.kozyheat.com](http://www.kozyheat.com).

Les manuels d'installation en français et en anglais sont disponibles chez votre détaillant local. Visitez [www.kozyheat.com](http://www.kozyheat.com).

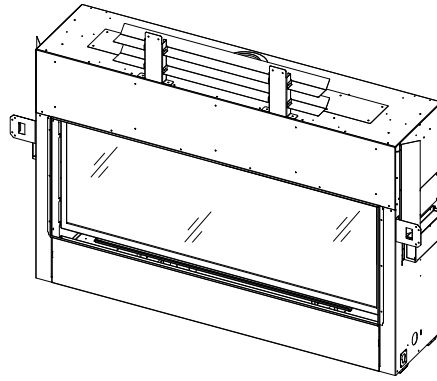

**⚠ WARNING:**  
**FIRE OR EXPLOSION HAZARD**  
Failure to follow safety warnings exactly could result in serious injury, death, or property damage.

- Do not store or use gasoline or other flammable vapors and liquids in the vicinity of this or any other appliance.
- **WHAT TO DO IF YOU SMELL GAS**
  - Do not try to light any appliance.
  - Do not touch any electrical switch; do not use any phone in your building.
  - Leave the building immediately.
  - Immediately call your gas supplier from a neighbor's phone. Follow the gas supplier's Instructions.
  - If you cannot reach your gas supplier, call the fire department.
- Installation and service must be performed by a qualified installer, service agency or the gas supplier

This appliance may be installed in an aftermarket, permanently located, manufactured home (USA only) or mobile home, where not prohibited by local codes.

This appliance is only for use with the type of gas indicated on the rating plate. A conversion kit is supplied with the appliance.



# DANGER



**HOT GLASS WILL  
CAUSE BURNS**  
**DO NOT TOUCH GLASS  
UNTIL COOLED**  
**NEVER ALLOW CHILDREN  
TO TOUCH GLASS**

A barrier designed to reduce the risk of burns from the hot viewing glass is provided with this appliance and shall be installed for the protection of children and other at-risk individuals.

INSTALLER: Leave this manual with the appliance.

CONSUMER: Retain this manual for future reference.



# CONGRATULATIONS!

Hussong Manufacturing welcomes you as a new owner of a Kozy Heat gas fireplace. Kozy Heat products are designed with superior components and materials, assembled with care by trained craftsmen who take pride in their work. To ensure you receive a quality product, the burner and valve assembly are 100 percent test-fired, and the complete fireplace is thoroughly inspected before packaging. Our commitment to quality and customer satisfaction has remained the same for over 40 years. We offer a complete line of gas, wood, and electric fireplaces, along with stylish accessories to complement any decor. Adding a fireplace is one of the best ways to increase the value of your home, and we are proud to offer a network of dealers throughout the country to help make your experience everything you imagine. We pride ourselves in being dedicated not only to functionality and reliability, but also customer safety. We offer our continual support and guidance to help you achieve the maximum benefit and enjoyment from your Kozy Heat gas fireplace.

Jim Hussong  
President

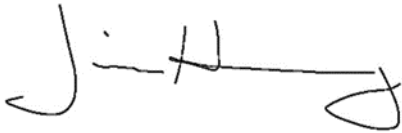

Dudley Hussong  
Board Chairman



Read this manual before installing or operating this appliance  
Please retain this owner's manual for future reference.

Homeowner Reference Information

Model Name: \_\_\_\_\_

Serial Number: \_\_\_\_\_

Dealership purchased from: \_\_\_\_\_

Dealership phone number: \_\_\_\_\_

Notes: \_\_\_\_\_

\_\_\_\_\_

\_\_\_\_\_

We recommend you record the following Information:

Date Purchased / Installed: \_\_\_\_\_

Location of fireplace: \_\_\_\_\_



# TABLE OF CONTENTS

<b>HOMEOWNER REFERENCE INFORMATION .....</b>	<b>3</b>	<b>8.0 Venting .....</b>	<b>39</b>
<b>TABLE OF CONTENTS .....</b>	<b>5</b>	8.1 Approved Vent Systems .....	39
<b>1.0 Introduction.....</b>	<b>7</b>	8.2 Venting Requirements .....	40
1.1 Appliance Certification .....	7	8.3 Vent Restriction.....	40
1.2 California Proposition 65 Warning .....	7	8.4 Use of Flexible Venting Outside the Appliance Enclosure.....	40
1.3 Requirements for the Commonwealth of Massachusetts.....	7	8.5 Natural Draft Co-Axial Vent Pipe Installations .....	41
<b>2.0 Specifications .....</b>	<b>8</b>	8.6 Class A Chimney / Masonry Chimney Conversion.....	45
2.1 Heating Specifications .....	8	<b>9.0 Fireplace Setup .....</b>	<b>46</b>
2.2 Electrical Specifications .....	9	9.1 Glass Frame Assembly.....	46
2.3 Appliance Dimensions .....	9	9.2 Component Access Tray .....	47
2.4 Safety Barrier Information .....	10	9.3 Light Kits.....	47
<b>3.0 Framing .....</b>	<b>11</b>	9.4 NK60TL-500 Log Set Installation .....	49
3.1 Appliance Placement Considerations.....	11	9.5 Control Board Removal and Installation .....	50
3.2 Appliance Design Options .....	11	<b>10.0 Electrical Information.....</b>	<b>52</b>
3.3 Floor Support and Protection.....	11	10.1 Electrical Specifications .....	52
3.4 Setting the Appliance .....	12	10.2 Wiring Requirements .....	52
3.5 Stand-Off Assembly and Installation .....	13	<b>11.0 Operating Instructions .....</b>	<b>55</b>
3.6 Nailing Flange Assembly and Installation .....	14	11.1 Setup Proflame 2 IFC Module.....	56
3.7 Clearance to Combustibles.....	15	11.2 Initialize the Control System.....	56
3.8 Wall Enclosure Rough Framing.....	17	11.3 Reset the System for Manual Operation .....	56
3.9 Vent Termination Framing .....	18	11.4 Automatic Safety Turn-off .....	56
3.10 Outdoor Covered Fireplace Installation .....	21	11.5 Backup Battery Operation .....	56
<b>4.0 Heat Management .....</b>	<b>23</b>	11.6 Control System 7 Day Timeout.....	57
4.1 Appliance Preparation for Komfort Zone Kit.....	23	11.7 IFC Module Ignition Sequence.....	57
4.2 Appliance Preparation for an Interior or Exterior Heat Transfer Kit.....	25	11.8 Additional Diagnostic Information .....	57
<b>5.0 Facing and Finishing .....</b>	<b>27</b>	11.9 Remote Control Operation .....	58
5.1 Standard Installation - Facing and Finishing Requirements .....	27	<b>12.0 Pressure Testing and Burner Adjustments.....</b>	<b>64</b>
5.2 Rectangle Surround Installation .....	34	12.1 Pressure Testing .....	64
5.3 Safety Barrier Installations .....	35	12.2 Flame Appearance Adjustment .....	65
<b>6.0 Gas Line Connection .....</b>	<b>36</b>	<b>13.0 Troubleshooting.....</b>	<b>68</b>
6.1 Gas Conversions .....	36	<b>14.0 Maintenance.....</b>	<b>71</b>
6.2 Gas Line Installation .....	36	14.1 Firebox.....	71
<b>7.0 Termination Locations.....</b>	<b>37</b>	14.2 Fan.....	71
7.1 Vertical Vent Cap Termination .....	37	14.3 Vent System.....	71
7.2 Minimum Termination Clearances .....	38	14.4 Glass Assembly .....	71
		14.5 Burner and Pilot System .....	72
		<b>15.0 Replacement Parts List.....</b>	<b>74</b>
		<b>Limited Lifetime Warranty .....</b>	<b>76</b>



# 1.0 Introduction

## 1.1 Appliance Certification

Laboratory: PFS in Cottage Grove, Wisconsin

Standards:

- ANSI Z21.88-2019/CSA 2.33-2019, Vented Gas Fireplace Heaters
- CSA 2.17 2017, Gas-Fired Appliances for Use at High Altitudes

This installation must conform with local codes, or in the absence of local codes, with the National Fuel Gas Code, ANSI Z223.1/NFPA 54, or the Natural Gas and Propane Installation Code, CSA B149.1.

## 1.2 California Proposition 65 Warning

**⚠ WARNING:** This product can expose you to chemicals including Carbon Monoxide, that is an externally vented by-product of fuel combustion, which is [are] known to the State of California to cause birth defects or other reproductive harm. For more information, visit [www.P65Warnings.ca.gov](http://www.P65Warnings.ca.gov).

## 1.3 Requirements for the Commonwealth of Massachusetts

The following requirements reference various Massachusetts and national codes not contained in this manual.

For all sidewall horizontally vented gas fueled equipment installed in every dwelling, building or structure used in whole or in part for residential purposes, including those owned or operated by the Commonwealth and where the side wall exhaust vent termination is less than (7) feet above finished grade in the area of the venting, including but not limited to decks and porches, the following requirements shall be satisfied:

### 1.3.1 Installation of Carbon Monoxide Detectors

At time of installation of side wall horizontally vented gas fueled equipment, the installing plumber or gas-fitter shall observe that a hard wired carbon monoxide detector with an alarm and battery back-up is installed on the floor level where the gas equipment is to be installed. In addition, the installing plumber or gas-fitter shall observe that a battery operated or hard wired carbon monoxide detector is installed on each additional level of the dwelling, building or structure served by the side wall horizontal vented gas fueled equipment. It shall be the responsibility of the property owner to secure the services of qualified licensed professionals for the installation of hard wired carbon monoxide detectors.

In the event that the side wall horizontally vented gas fueled equipment is installed in a crawl space or attic, the hard wired carbon monoxide detector with alarm and battery back-up may be installed on the next adjacent floor level. In the event that the requirements of this subdivision can not be met at the time of completion of installation, the owner shall have a period of thirty (30) days to comply with the above requirements; provided, however, that during said thirty (30) day period, a battery operated carbon monoxide detector with an alarm shall be installed.

## 1.3.2 Approved Carbon Monoxide Detectors

Each carbon monoxide detector as required in accordance with the above provisions shall comply with NFPA 720 and be ANSI/UL 2034 listed and IAS certified.

## 1.3.3 Signage

A metal or plastic identification plate shall be permanently mounted to the exterior of the building at a minimum of eight (8) feet above grade directly in line with the exhaust vent terminal for the horizontally vented gas fueled heating appliance or equipment. The sign shall read, in print no less the one-half inch (½) in size, "GAS VENT DIRECTLY BELOW. KEEP CLEAR OF ALL OBSTRUCTIONS".

## 1.3.4 Inspection

The state or local gas inspector of the side wall horizontally vented gas fueled equipment shall not approve the installation unless, upon inspection, the inspector observes carbon monoxide detectors and signage installed in accordance with the provisions of 248 CMR 5.08 (2) (a) 1 through 4.

## 1.3.5 Exemptions

The following equipment is exempt from 248 CMR 5.08 (2) (a) 1 through 4: The equipment listed in Chapter 10 entitled "Equipment Not Required To Be Vented" in the most current edition of NFPA 54 as adopted by the Board; and Product Approved side wall horizontally vented gas fueled equipment installed in a room or structure separate from the dwelling, building or structure used in whole or in part for residential purposes.

## 1.3.6 Manufacturer Requirements

### 1.3.6.1 Gas Equipment Venting System Provided

When the manufacturer of Product Approved side wall horizontally vented gas equipment provides a venting system design or venting system components with the equipment, the instructions provided by the manufacturer for installation of the equipment and the venting system shall include:

- Detailed instructions for the installation of the venting system design or the venting system components; and
- A complete parts list for the venting system design or venting system.

### 1.3.6.2 Gas Equipment Venting System NOT Provided

When the manufacturer of Product Approved side wall horizontally vented gas equipment does not provide the parts for venting the flue gases, but identifies "special venting systems", the following requirements shall be satisfied by the manufacturer:

- The referenced "special venting systems" instructions shall be included with the appliance or equipment installation instructions and;
- The "special venting systems" shall be Product Approved by the Board, and the instructions for that system shall include a parts list and detailed installation instructions.

A copy of all installation instructions for all Product Approved side wall horizontally vented gas fueled equipment, all venting instructions, all parts lists for venting instructions, and/or all venting design instructions shall remain with the appliance or equipment at the completion of the installation.

## 2.0 Specifications

### 2.1 Heating Specifications

	Natural Gas	Propane
<b>Maximum Input Rating</b>	51,000 Btu/h (14.95 kW)	51,000 Btu/h (14.95 kW)
<b>Orifice Size (DMS)</b>	Left: #48 Center: #48 Right: #48 Bottom: #54	Left: #1.10mm Center: #1.10mm Right: #1.10mm Bottom: #65
<b>Minimum Input Rating</b>	34,000 Btu/h (9.96 kW)	40,000 Btu/h (11.72 kW)
<b>Minimum Inlet Pressure</b>	5" WC (1.25 kPa) 7" WC (1.74 kPa) recommended	11" WC (2.74 kPa)
<b>Maximum Inlet Pressure</b>	10" WC (2.49 kPa)	13" WC (3.24 kPa)
<b>Manifold Pressure (High)</b>	3.5" WC (0.87 kPa)	10" WC (2.49 kPa)
<b>Manifold Pressure (Low)</b>	1.6" WC (0.40 kPa)	6.4" WC (1.59 kPa)
<b>Venturi Opening Settings</b>	Left: 1/8" (3mm) Center: 1/8" (3mm) Right: 1/8" (3mm) Bottom: 1/8" (3mm)	Left: 1/2" (13mm) Center: 1/2" (13mm) Right: 1/2" (13mm) Bottom: 3/8" (10mm)

#### 2.1.1 Burner Identification

- Figure 2.1 identifies how the burners are referenced throughout this manual for burner orifice size, venturi settings, or other burner information.

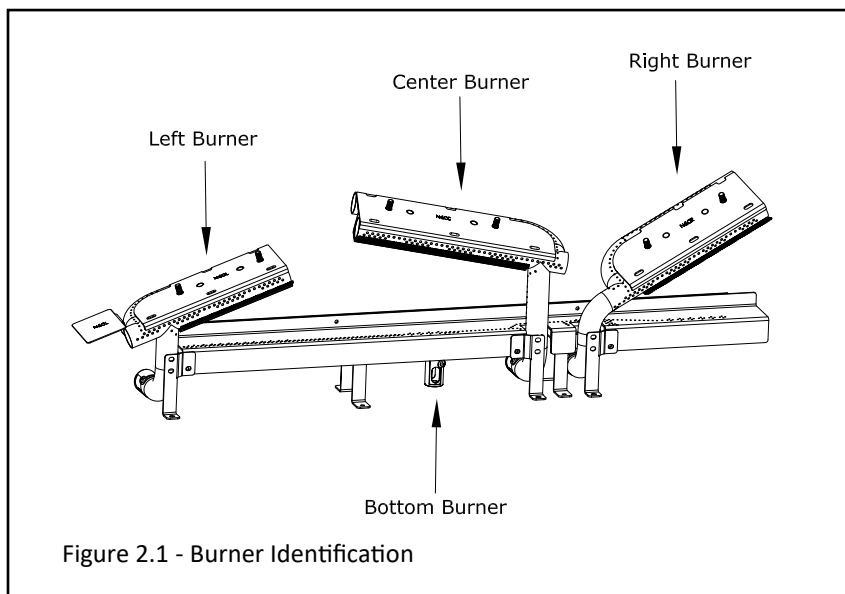



## 2.1.2 Altitude Adjustment

This appliance may be installed at higher altitudes. Please refer to National Fuel Gas Code ANSI Z223.1/NFPA 54, CSA-B149.1 Natural Gas and Propane Installation Code, local authorities, or codes having jurisdiction in your area regarding derate guidelines.

### 2.1.2.1 US Installations

Refer to the American Gas Association guidelines for the gas designed appliances derating method. For elevations above 2,000' (610m), input ratings are to be reduced by 4% for each 1,000' (305m) above sea level.

### 2.1.2.2 Canadian Installations

When the appliance is installed at elevations above 4,500' (1,372m), the certified high-altitude rating shall be reduced at the rate of 4% for each additional 1,000' (305m).

## 2.2 Electrical Specifications

- The junction box in this appliance requires 120VAC, 60Hz, and 6 Amps.
- Verify the household breaker is shut off prior to working on any electrical lines.
- The AC power supply to this appliance must be hot at all times and shall not have a switch installed in it.

## 2.3 Appliance Dimensions

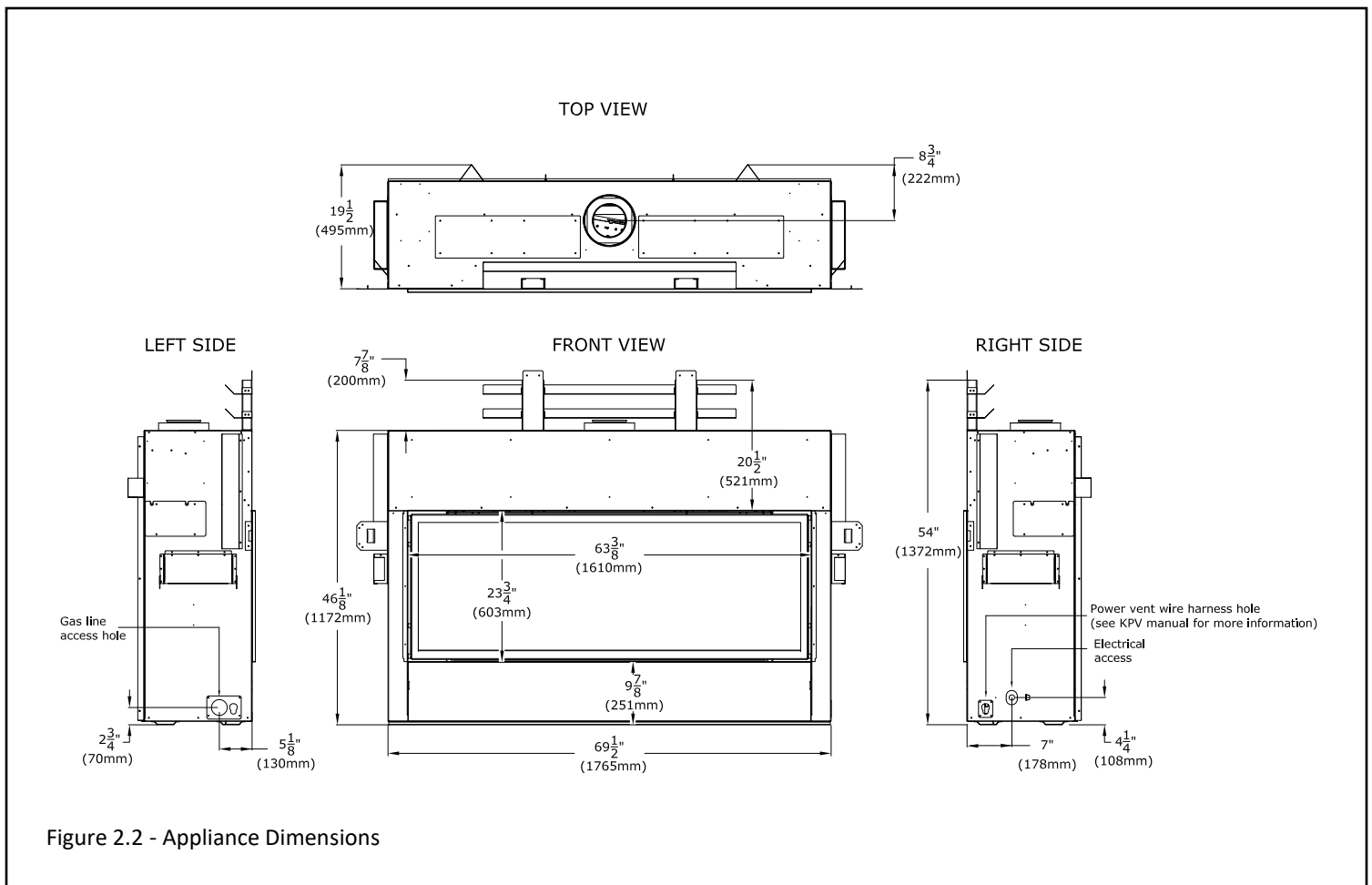

## 2.4 Safety Barrier Information

WARNING: A barrier designed to reduce the risk of burns from the hot viewing glass is provided with this appliance and shall be installed for the protection of children and other at-risk individuals.

If the barrier becomes damaged, the barrier shall be replaced with Hussong Mfg.'s barriers for this appliance.

Please refer to Section 5.3 Safety Barrier Installation for installation information.

Any safety screen, guard, or barrier removed for servicing an appliance must be replaced prior to operating the appliance

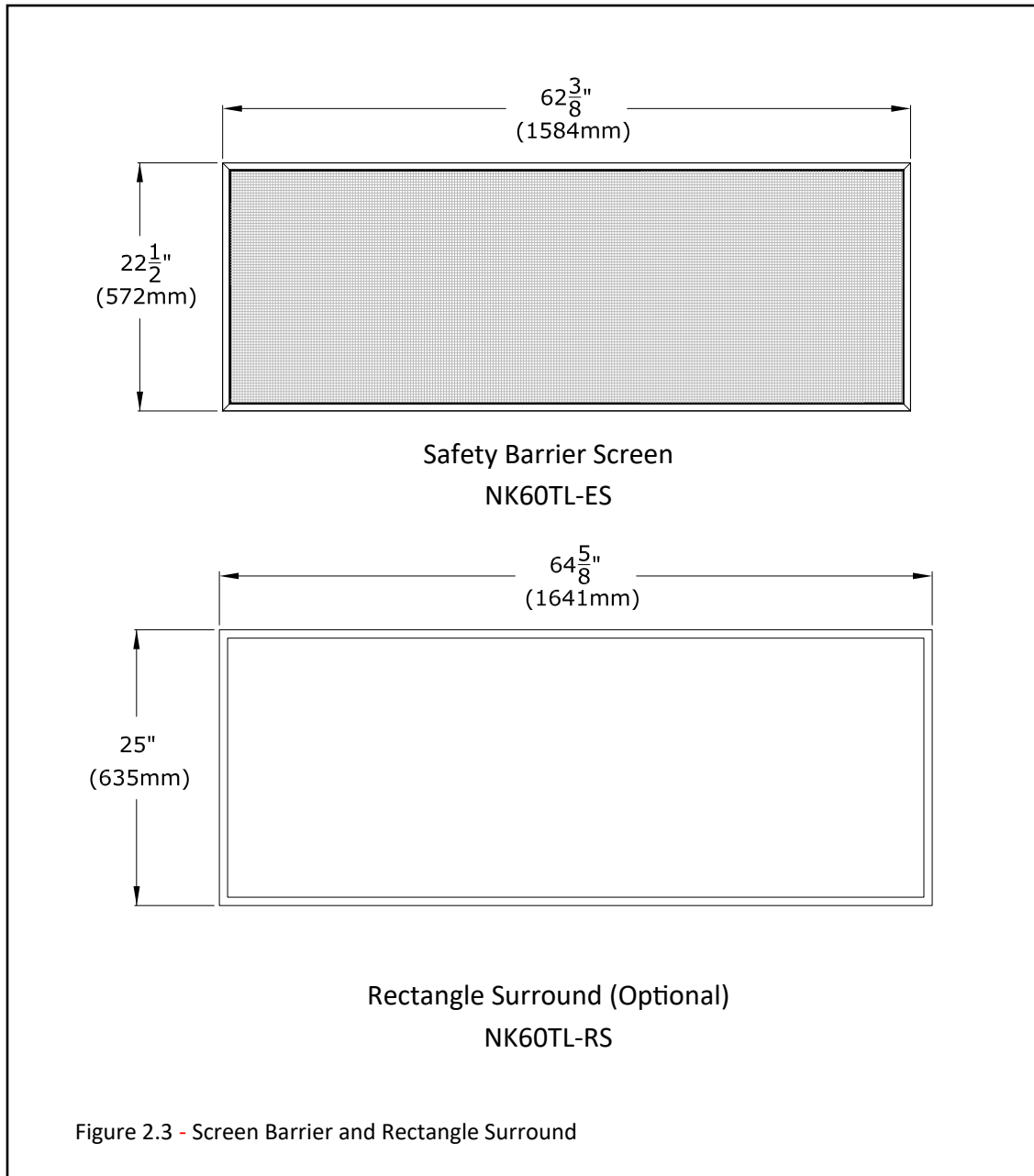

## 3.0 Framing

---

### 3.1 Appliance Placement Considerations

Read all documentation for your specific installation and design options prior to appliance installation.

**WARNING: Due to high temperatures, the appliance should be located out of traffic and away from furniture and draperies.**

**FIRE HAZARD: Do NOT install this appliance directly on carpeting, vinyl, or any other combustible material other than wood.**

**Children and adults should be alerted to the hazards of high surface temperature and should stay away to avoid burns or clothing ignition**

**Young children should be carefully supervised when they are in the same room as the appliance. Toddlers, young children, and others may be susceptible to accidental contact burns. A physical barrier is recommended if there are at-risk individuals in the house. To restrict access to a fireplace or stove, install an adjustable safety gate to keep toddlers, young children, and other at-risk individuals out of the room and away from hot surfaces**

Note: Unless otherwise noted all clearances / images in this manual are based off of nominal 2" x 4" framing being used.

- This appliance must be installed on a level surface capable of supporting the fireplace and venting. If possible, place the fireplace in a position where the vent terminates between two studs, eliminating the need for any additional framing.
- This fireplace may be installed in a bedroom.
- Please be aware of the large amount of heat this fireplace will produce when determining a location.
- If planning to convert to Propane, it is easier to complete the gas conversion before installing the fireplace in the framed opening.

### 3.2 Appliance Installation Options

This appliance offers several design options for managing the heat produced by this fireplace.

**Note: When deciding on which design option suites your application please review all sections throughout this manual as different design options have different framing, facing, and finishing options and requirements.**

- **Standard Installation** will be outlined in this manual in sections marked 'standard installation' and must be followed if no design options (Komfort Zone Kit) are to be used. The fireplace chamber and ceiling minimum height must be 80" (2032mm) for standard installations.
- **Komfort Zone Kit (KZK)** offers the option to redistribute radiant heat through a plenum. This option allows for combustible facing materials above the fireplace, heat reduction for a TV above the fireplace, and lower mantel clearances. See section 4.0, Heat Management. If installing a Komfort Zone Kit (#KZK-062), the framing requirements may be different than the standard dimensions listed in this section. Please reference the manual included with your kit before completing all fireplace framing and other installation considerations. The fireplace chamber and ceiling minimum height must be 80" (2032mm) for KZK options.

- **Heat Transfer Kit(s)** allows you to transfer heat to a specific area inside your home (interior) or directly outside (exterior). This appliance can have (2) heat transfer kits installed at the same time. It can be up to two of the same heat transfer kits, or a combination of interior and exterior kits. See the HTK-EXT and/ or HTK-INT manuals for further information. If you are planning a standard installation with the use of an exterior and/ or interior kit, the minimum dimensions listed in this section will apply for your framing installation. You will need to remove the cover plates as instructed in section 4.2.. If you are installing a heat transfer kit with the use of a Komfort Zone Kit, the minimum requirements applicable to those options must be adhered to.
- **Kozy Power Vent** is a fan-powered mechanical draft vent system (horizontal terminations only) for use with any of the design options listed previously in this section (Standard or Komfort Zone Kit). Reference the #KPV manual for all system requirements. Utilizing the Kozy Power Vent system will not change facing and finishing requirements or safety barrier requirements from the Standard or Komfort Zone Kit design options.

### 3.3 Floor Support and Protection

- Floor protection in front of the fireplace is not required. Combustible material may be used if installing a hearth extension. Consider the thickness of the hearth extension finishing material if building a fireplace platform.
- If this appliance is to be installed directly on carpeting, tile, or other combustible material other than wood flooring, this appliance shall be installed on a metal or wood panel extending the full width and depth of the appliance.
- If the appliance is to be installed above floor level, a solid, continuous platform must be constructed below the appliance.

### 3.4 Setting the Appliance

This section outlines general information on setting the appliance in the framed opening and starting the installation process.

Decide on your appliance installation option mentioned in Section 3.2 before setting the appliance. Your framing requirements, clearance to combustibles, and vent configuration will depend upon this decision.

**IMPORTANT:** If you are using a Kozy Zone Kit and/or Heat Transfer Kit option refer to Section 4.0 for additional preparation steps that must be completed before setting the appliance in the framed opening.

#### General Procedure

1. Frame your opening based on your selected appliance installation option. Refer to Section 3.8 for information for the framed opening of the standard installation option. If you are using a KZK installation option refer to the KZK manual for framing.
2. Lay out the path for your vent run before installing appliance.
3. Install the nailing flanges on the appliance. Refer to Section 3.6 for assembly and installation. The nailing flanges are where you secure your appliance to the framed opening. The framing will be flush with the appliance when it is installed.
4. Assemble and install the top stand-off assembly. Refer to Section 3.5 for more information on the top stand-off assembly. This stand-off assembly provides the necessary thermal protection of the header.
5. Place the fireplace inside the framed opening and secure the appliance into the framing. The fireplace will be flush with the framing.
6. The next steps would involve installing the KZK (if applicable), vent pipe, connect gas line, connect electrical wiring, and finally finishing material.

#### 3.4.1 Moving the Appliance

This appliance is heavy. We recommend a team lift when moving, placing, and positioning the appliance.

On both sides of the appliance, there are lift handles that allow a hand lift (no sharp edges), or allow a 2" x 4" piece of lumber to be inserted inside the lift handles, as shown in FIGURE 3.1.

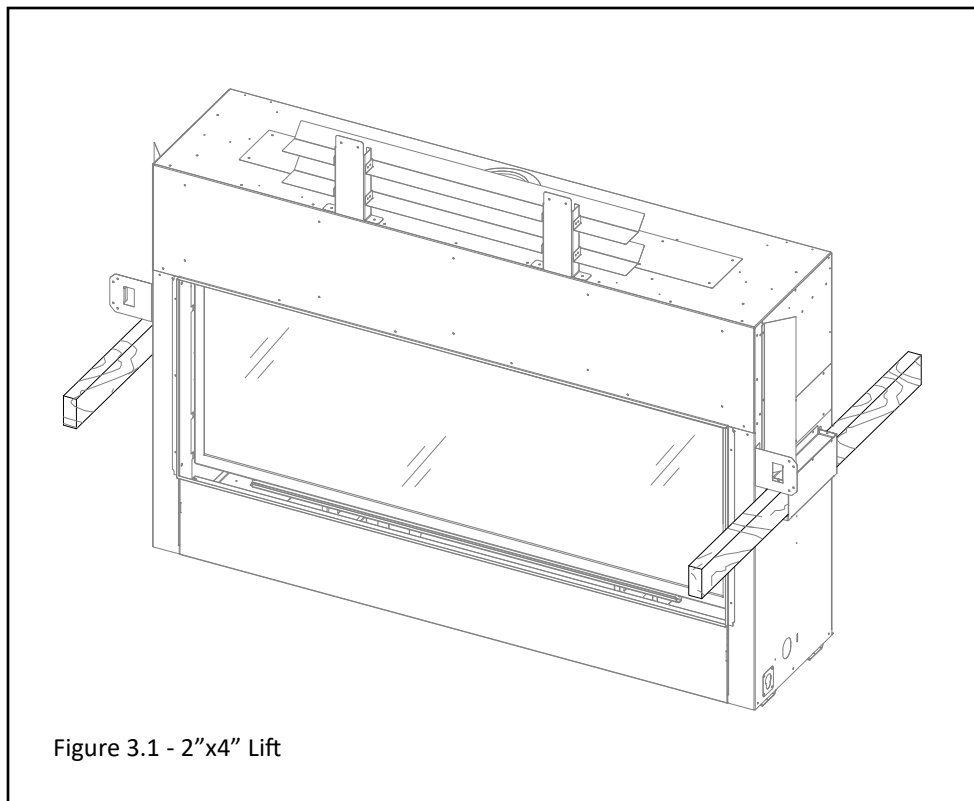

Figure 3.1 - 2"x4" Lift

### 3.5 Stand-Off Assembly and Installation

**WARNING:** The top stand-offs provide the 7-7/8" (200mm) minimum clearance to the header. Use only non-combustible material in this area for the entire width of the fireplace. DO NOT use wood, sheetrock, et cetera, in this zone.

Top stand-off brackets must be formed and attached prior to positioning fireplace into framed opening.

Note: If installing Kozy Zone Kit or Heat Transfer Kit complete the necessary preparation work before assembling the stand-off assembly.

Note: Screws for the installation steps below are provided in the fireplace components packet.

Installation:

1. Locate the stand-off heat shields and stand-off brackets that are shipped with the fireplace.
2. Attach the top stand-off brackets with (4) screws to the top of the fireplace as shown in Figure 3.1.
3. Take the horizontal heat shields and bend the tabs upward that have the screw holes.
4. Attach the horizontal heat shields to the top stand-off brackets with the (8) screws as shown in Figure 3.1.

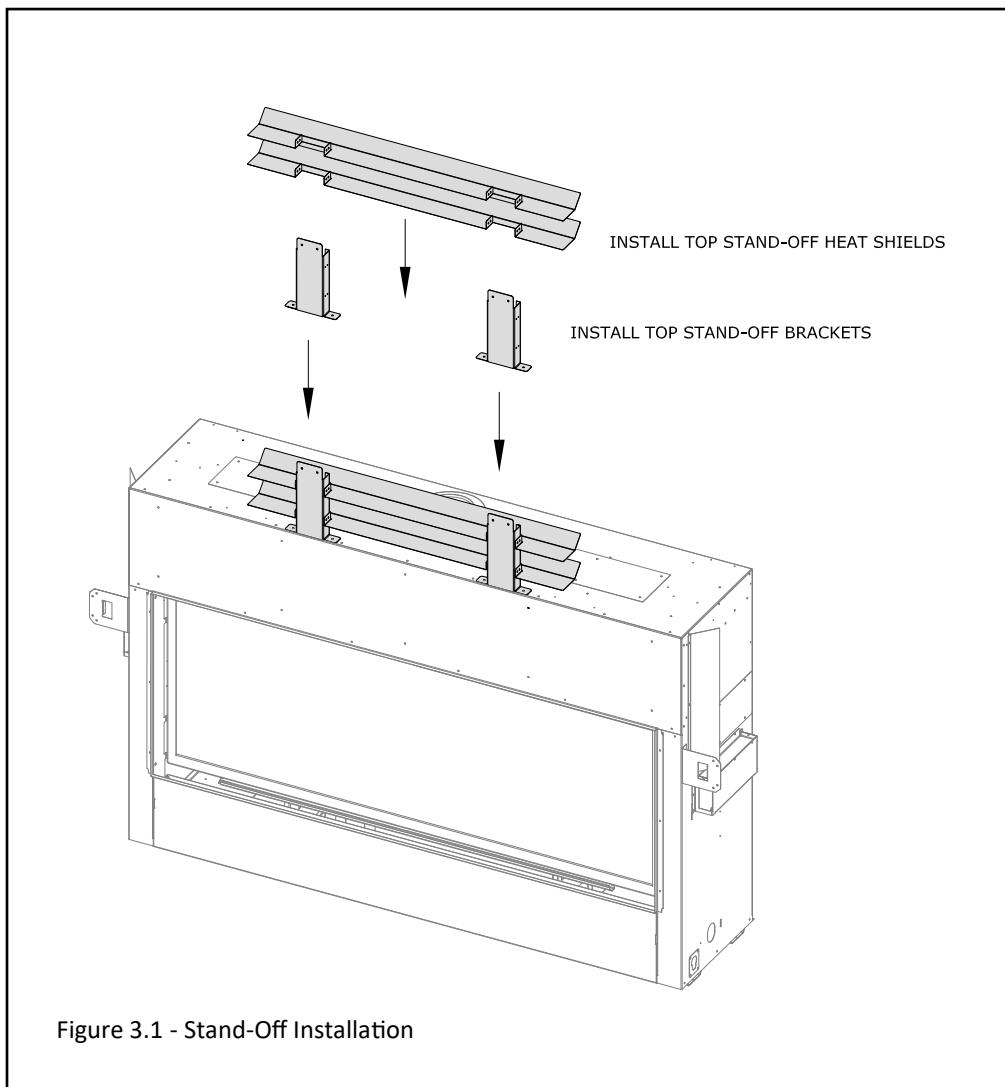

### 3.6 Nailing Flange Assembly and Installation

CAUTION: Never permanently remove these assemblies from the fireplace. They must be secured regardless of finish material used.

1. Remove (2) nailing flanges from the right and left side of the fireplace.
2. Align nailing flange with holes on outside corners of fireplace, with the stand-off flanges on the nailing flanges facing away from the fireplace

3. Secure the nailing flanges to the fireplace with screws (provided) through the slots in nailing flanges.
4. Bend perforation on nailing flange until parallel with fireplace face. Do not bend toward fireplace face.
5. Position framing stud against the small stand-off (located on backside of nailing flange). Secure with nails or screws.

When installed, the nailing flanges provide the minimum 3-1/4" (83mm) clearance from the sides of the fireplace to framing.

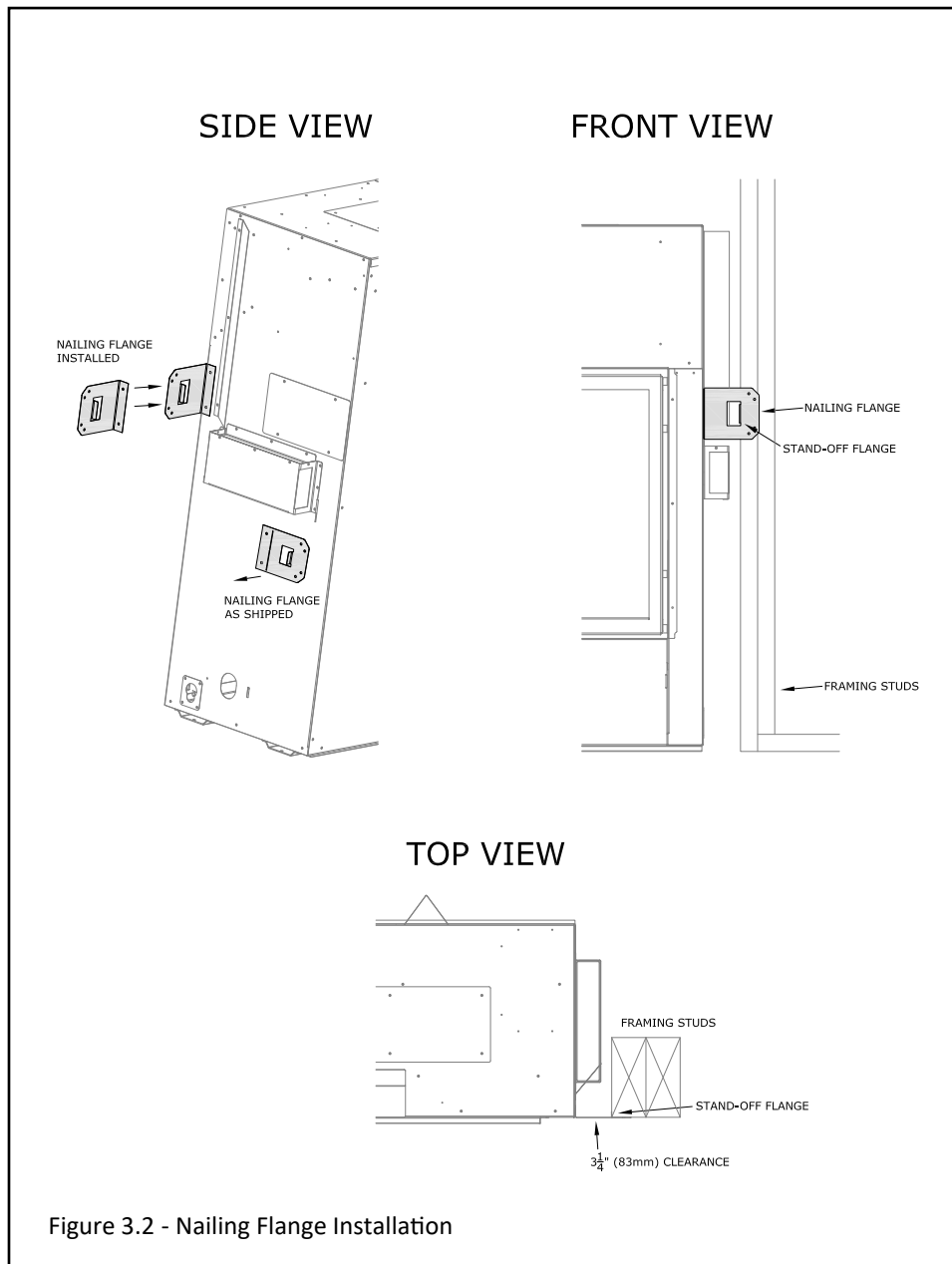

### 3.7 Clearances to Combustibles

- See Table 3.1 below for minimum clearances for the standard installation option.
- See Figure 3.3 on the following pages for typical standard installation options.
- Unless otherwise noted all clearances / images in this manual are based off of nominal 2" x 4" framing being used.

**IMPORTANT: Clearances may change when utilizing the Komfort Zone Kit (Part# KZK-062). Please reference the manual included with that kit.**

<b>Table 3.1, Minimum Fireplace Clearances to Combustible Material</b>		
Minimum height of fireplace enclosure	80"	2032mm
Base of the fireplace to ceiling	80"	2032mm
Fireplace top finishing edge to ceiling	46-3/8"	1178mm
From fireplace top stand-off brackets	0"	0mm
From fireplace left and right stand-off brackets (nailing flanges)	0"	0mm
From fireplace back stand-off brackets	0"	0mm
From fireplace corners	2-5/8"	67mm
From fireplace front	36"	914mm
Fireplace side finishing edge to adjacent sidewall	0"	0mm
Mantel 6" (152mm) deep from the top finishing edge of the fireplace	12"	305mm
Mantel 6" (152mm) deep from the base of the fireplace	45-5/8"	1159mm
<b>Minimum Vent System Clearances To Combustibles Inside Minimum Enclosure</b>		
Horizontal venting within minimum fireplace enclosure - Top surface of vent pipe	11-7/8"	302mm
Horizontal venting within minimum fireplace enclosure - Left, right, and bottom surfaces of vent pipe	1"	25mm
Vertical venting within minimum fireplace enclosure - All surfaces	1"	25mm

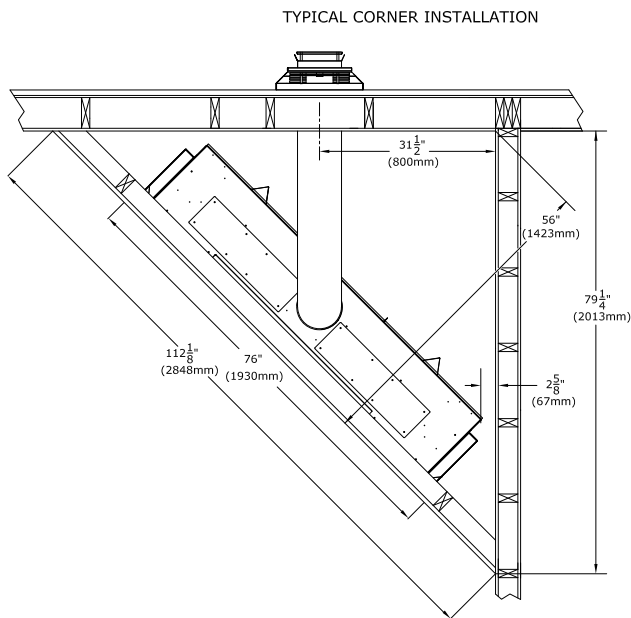
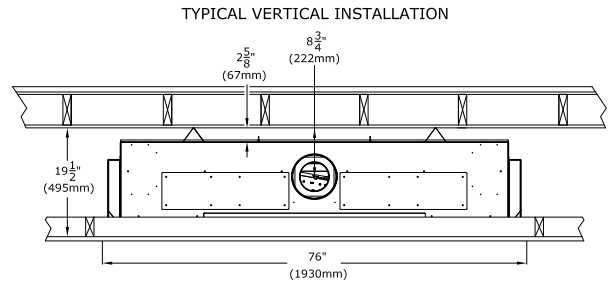
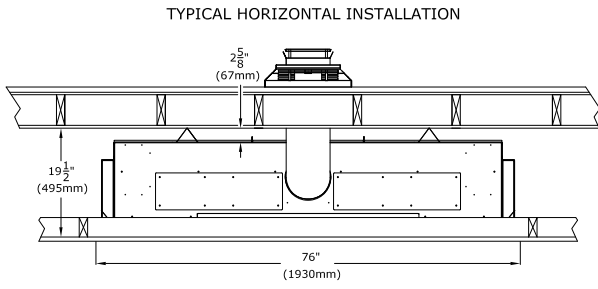

Nominal 2"x4" framing  
used in interior enclosure  
framing

Figure 3.3 - Typical Appliance Installation



### 3.8 Wall Enclosure Rough Framing

Note: Unless otherwise noted all clearances / images in this manual are based off of nominal 2" x 4" framing being used.

#### 3.8.1 Rough Framing

**WARNING:** Provide adequate clearances around air openings into the combustion chamber. Provide adequate clearance in front of the fireplace for barrier removal, component access, gas line installation, service access, etc.

**CAUTION:** Cold air transfer area. The surround fireplace chase must comply with all clearances as outlined in this manual, and be constructed in compliance with local building codes. Outside walls should be insulated to prevent cold air from entering room.

Rough-in dimensions outlined in FIGURE 3.4 below are the same for all design options and must be followed.

- Floor protection in front of the fireplace is not required. Combustible material may be used if installing a hearth extension. Consider the thickness of the hearth extension finishing material if building a fireplace platform. The hearth may be flush with the bottom finishing edge of the fireplace.
- The bottom of the fireplace must be placed directly on a wood or non-combustible surface (not linoleum or carpet). If this appliance is to be installed directly on carpeting, tile, or other combustible material other than wood flooring, this appliance shall be installed on a metal or wood panel extending the full width and depth of the appliance.

- Framing dimensions should allow for wall covering thickness and fireplace facing materials.
- If masonry (optional) is to be used, prepare the foundation necessary for the full masonry load. A lintel must be used over the top of the appliance to support the added weight of the masonry construction above the fireplace.

#### 3.8.2 Mounting a Television Above a Fireplace and Television Recess Construction

**WARNING:** All clearances to venting must be maintained.

- Mounting a television above a fireplace is a common practice. Mantel depth, ceiling heights, and wall and mantel construction material all affect television surface temperatures. Most television manufacturers specify in their instructions that a television should not be installed on, near, or above a heat source.
- If you want a Television above a fireplace it is highly recommended install the fireplace with the KZK installation design option. Refer to Section 3.2 for more information on the KZK design. Install the plenum discharge above the location of a television. This will help distribute heat from below the TV to above the TV. We also recommend the use of a mantel to deflect heat away from the television.
- Television location rests solely on the homeowner. It is the home owner's responsibility that the preferred TV mounting and mantel design will not exceed the listed maximum operation temperature of their electronic goods.
- The allowed TV recess of 4-1/4" (108mm) measures from the front of the nominal 2x4 framing to the backside of the finishing material of the pocket.

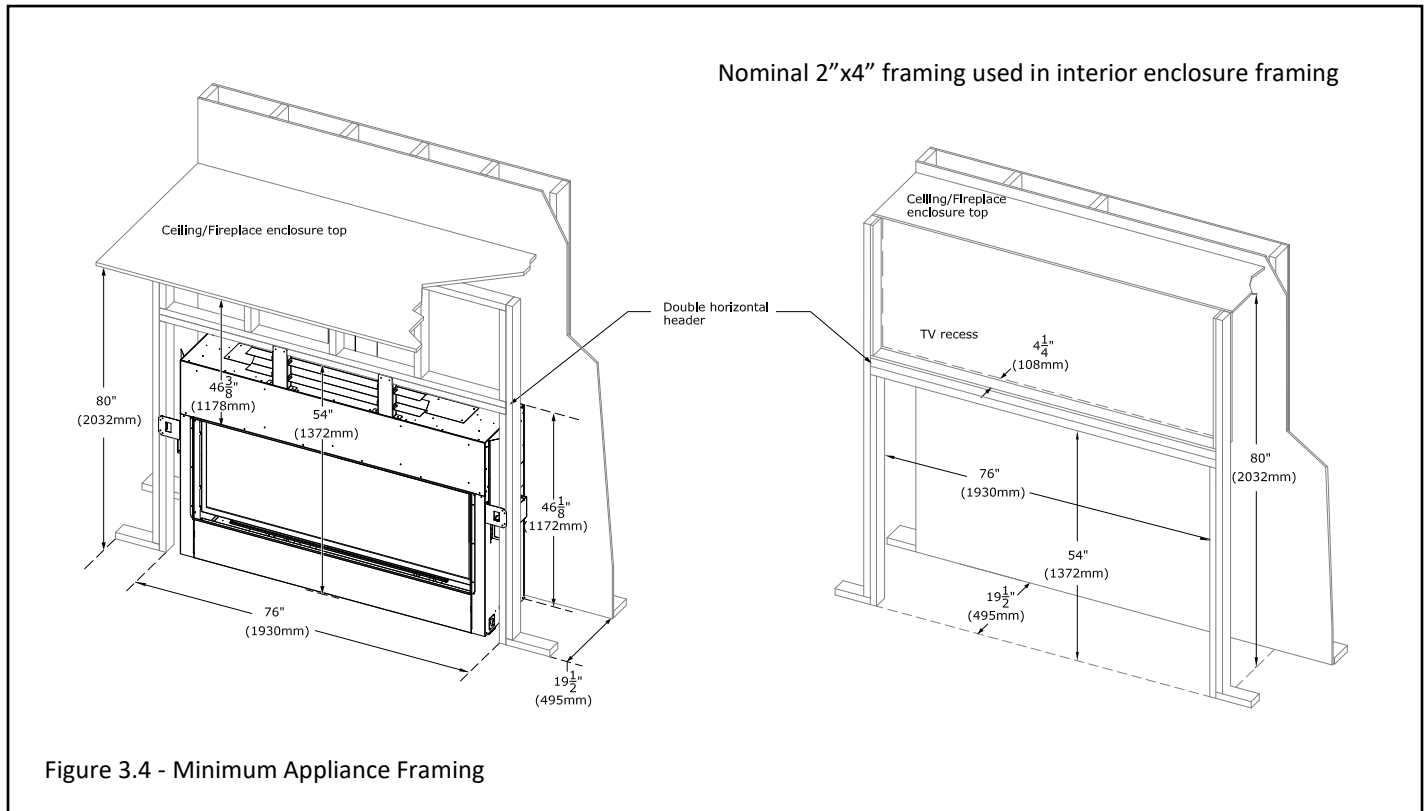

Figure 3.4 - Minimum Appliance Framing

### 3.9 Vent Termination Framing

The following information applies to all standard, and Komfort Zone Kit design options.

If using Kozy Power Vent #KPV, please reference the manual included with the kit.

#### 3.9.1 Vent Termination Location

- Natural Draft: Exterior vent termination location must be in compliance with section 7.0, TERMINATION LOCATIONS.
- Power Vent System: See the #KPV manual that came with the power vent system for termination location requirements

#### 3.9.2 Clearances

- A minimum of 1" (25mm) clearance on all sides of the vertical vent pipe must be maintained.
- See Section 3.9.2 for vent heat shield installation.

Refer to FIGURE 3.5 below for the following clearances

- A minimum of 1" (25mm) clearance from the top surface on the horizontal pipe must be maintained.
  - When the fireplace is installed at the minimum chamber height any horizontal venting must have a minimum clearance of 11-7/8" (302mm) from the top of the chamber. The horizontal pipe after the wall pass-through must maintain a 1" (25mm) clearance to combustibles on all surfaces of the pipe.
- A minimum of 1" (25mm) clearance on the sides and bottom surfaces on the horizontal pipe must be maintained.

NOTE: Elbows listed with approved vent systems for this appliance vary in vertical length. Please consult the vent manufacturer's instructions to determine the elbow dimension used for installation. Adjust the wall pass-through rough opening dimensions as necessary to maintain clearance requirements.

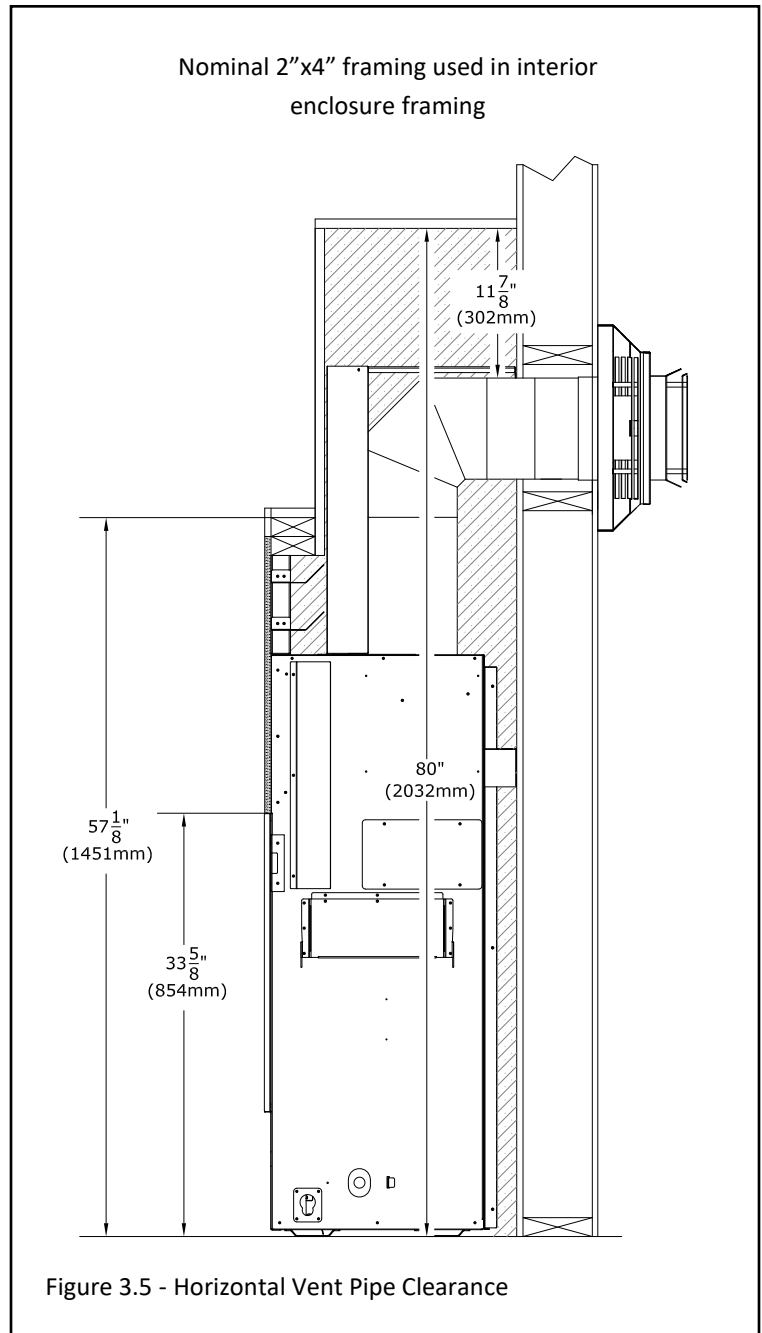

### 3.9.3 Vent Heat Shield Installation

- Vent heat shields must be installed.
- When the vent pipe terminates at the ceiling of the fireplace enclosure you only use the front vertical vent heat shield as shown in Figure 3.6.
- When the vent pipe terminates at the wall at the minimum vent run use the front vertical and top horizontal vent heat shield as shown in Figure 3.6.

### 3.9.3 Vertical Terminations

- Follow vent pipe manufacturer's installation instructions for vertical terminations.
- Attic insulation shields may be insulated using unfaced insulation products listed as non-combustible per ASTM E 136

### 3.9.4 Horizontal Terminations

**WARNING: Do not recess the vent cap into wall or siding.**

**IMPORTANT: Horizontal vent sections require 1/4" (6mm) rise for every 12" (305mm) of travel for natural draft applications.**

Wall thimble products that comply with the required 1" (25mm) top clearance to combustibles must be installed for all horizontal vent runs that pass through interior or exterior walls. These wall thimble products may be insulated using unfaced insulation products listed as noncombustible per ASTM E 136.

Elbows listed with approved vent systems for this appliance vary in vertical length. Please consult the vent manufacturer's instructions to determine the elbow dimension used for installation. Adjust the wall pass-through rough opening dimensions to maintain clearance requirements.

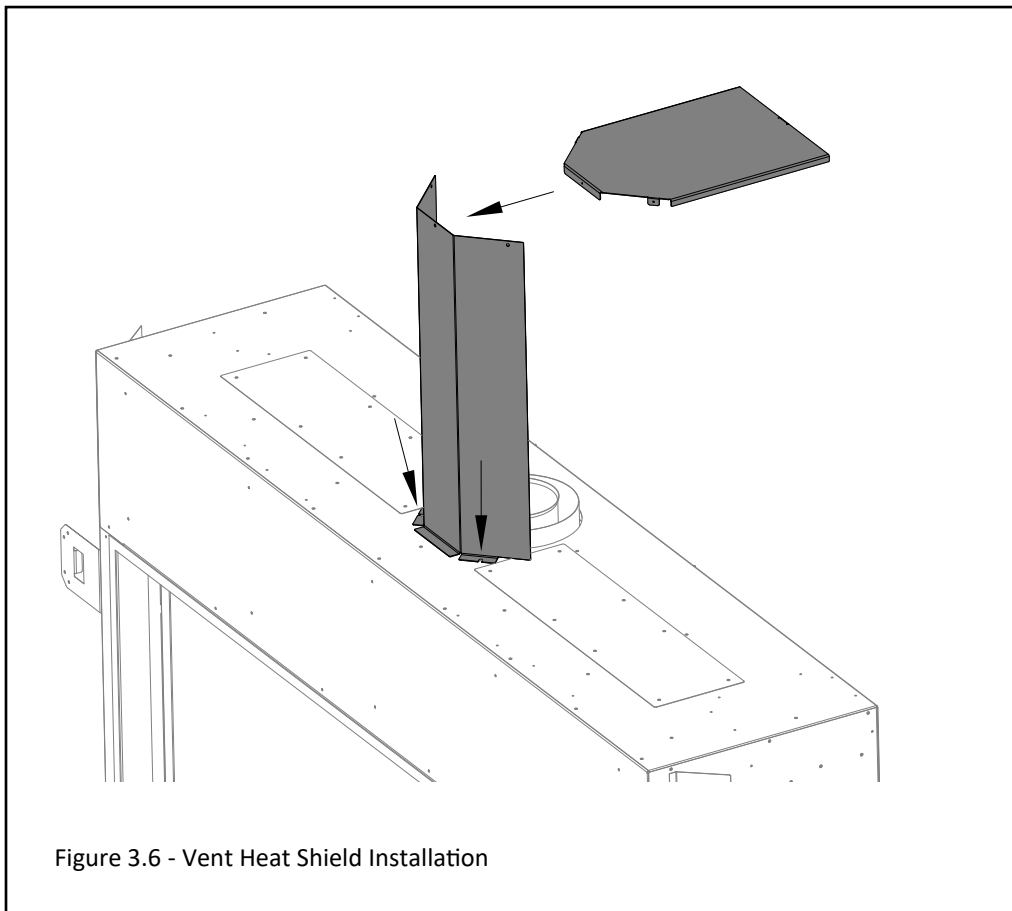

### 3.9.5 Wall Pass Through Framing Instructions

Follow FIGURE 3.7 below for minimum rough-in dimensions.

1. Measure from floor level of the fireplace to the center of where the vent pipe will penetrate the wall. The dimension in FIGURE 3.7 is used with a Simpson DuraVent elbow.
2. Cut and frame an opening in the wall to allow the vent system to run level through the wall pass-through.
3. Follow the vent pipe manufacturer's installation instructions for natural draft vent installation.

**Note: Vent pipe dimensions are tested with listed Simpson DuraVent pipe. Other manufacturers product dimensions may vary.**

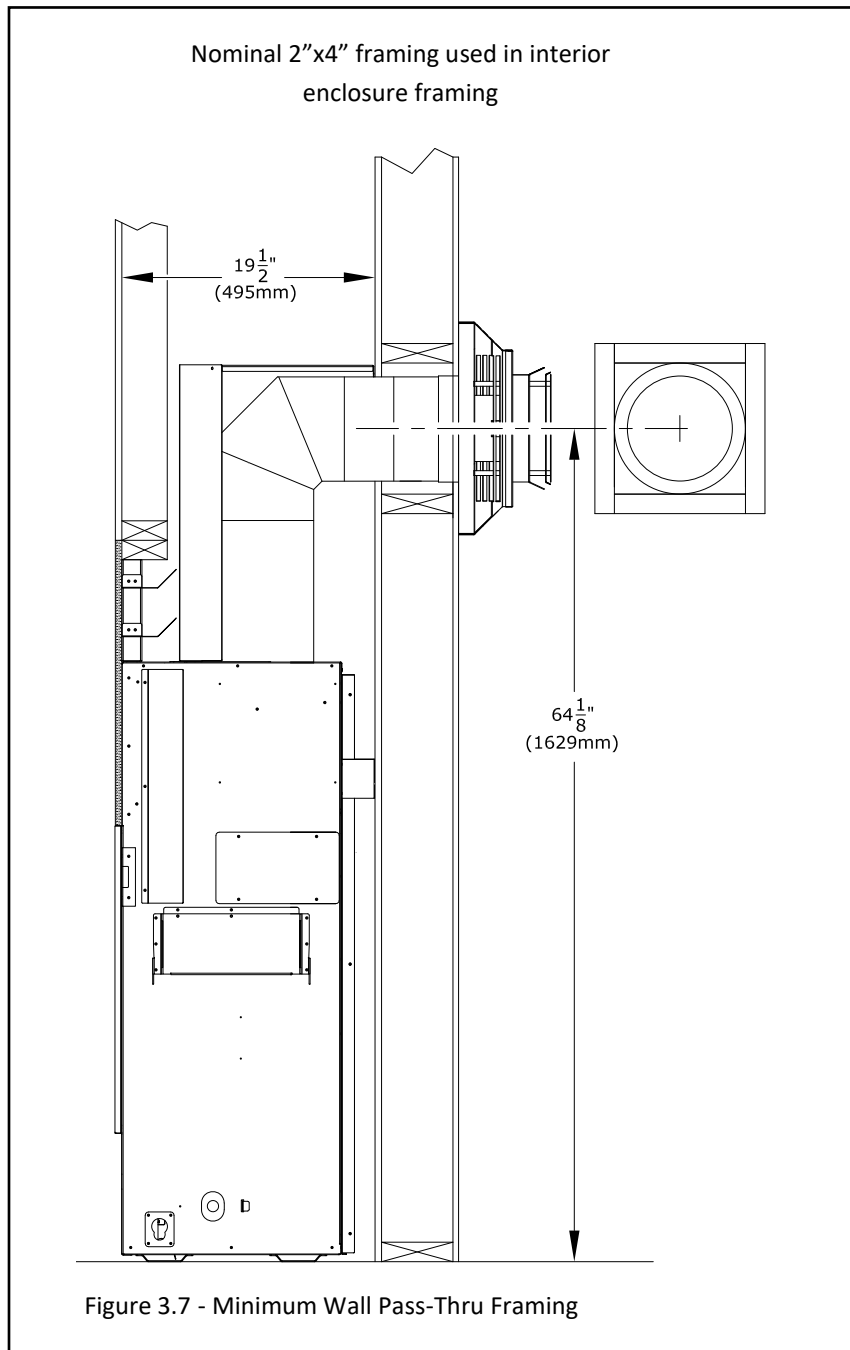

### 3.10 Outdoor Covered Fireplace Installation

A outdoor covered fireplace installation allows a fireplace to be installed in an outdoor covered area, where the appliance is protected from direct precipitation.

Follow the instructions and illustrations in this section for installation procedures.

#### 3.10.1 Safety Screen Barriers

Hussong Mfg. highly recommends to use black painted safety barriers in outdoor installations. Other screen barriers that incorporate a plated or patina finish are highly susceptible to oxidation and discoloration.

#### 3.10.2 Requirements

- The continuous insulated building envelope and weatherproof membrane are not to be interrupted by fireplace installation.
- Fireplace operation is approved from 40°F to 110°F.
- All wiring connections shall be in accordance with outdoor requirements of NECA NFPA 70.
- All clearances and requirements in your appliance manual must be adhered to.

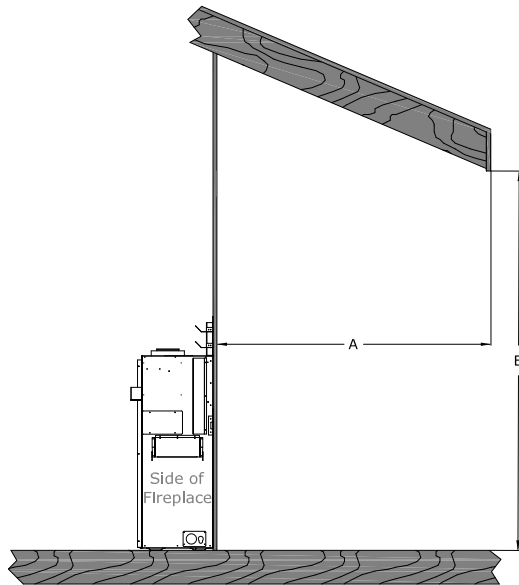

The overhang (A) must be a minimum of  $\frac{1}{2}$  or greater of the roofline elevation (B) above the base of the fireplace.

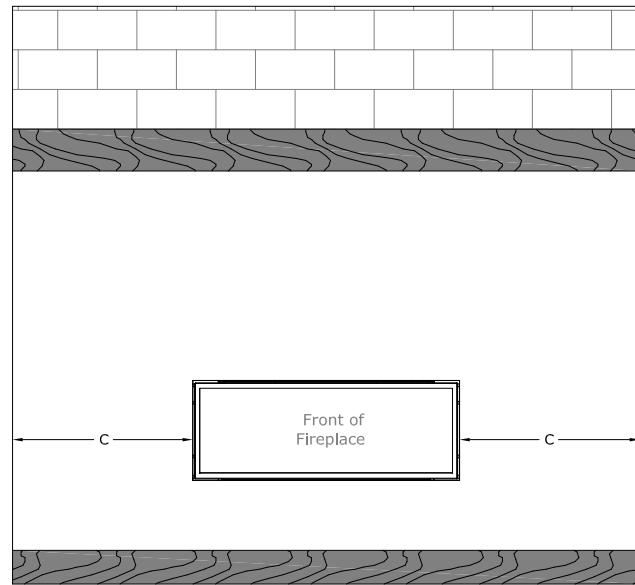

The width of the overhang to each side of the appliance (C) must be a minimum of  $\frac{1}{2}$  or greater of the roofline elevation (B) above the base of the fireplace.

Example: If the roofline (B) is 10' above the base of the fireplace, the overhang (A) must be 5' or greater and the width of the overhang to each side of the fireplace (C) must be 5' or greater.

Figure 3.8 - Outdoor Covered Installation

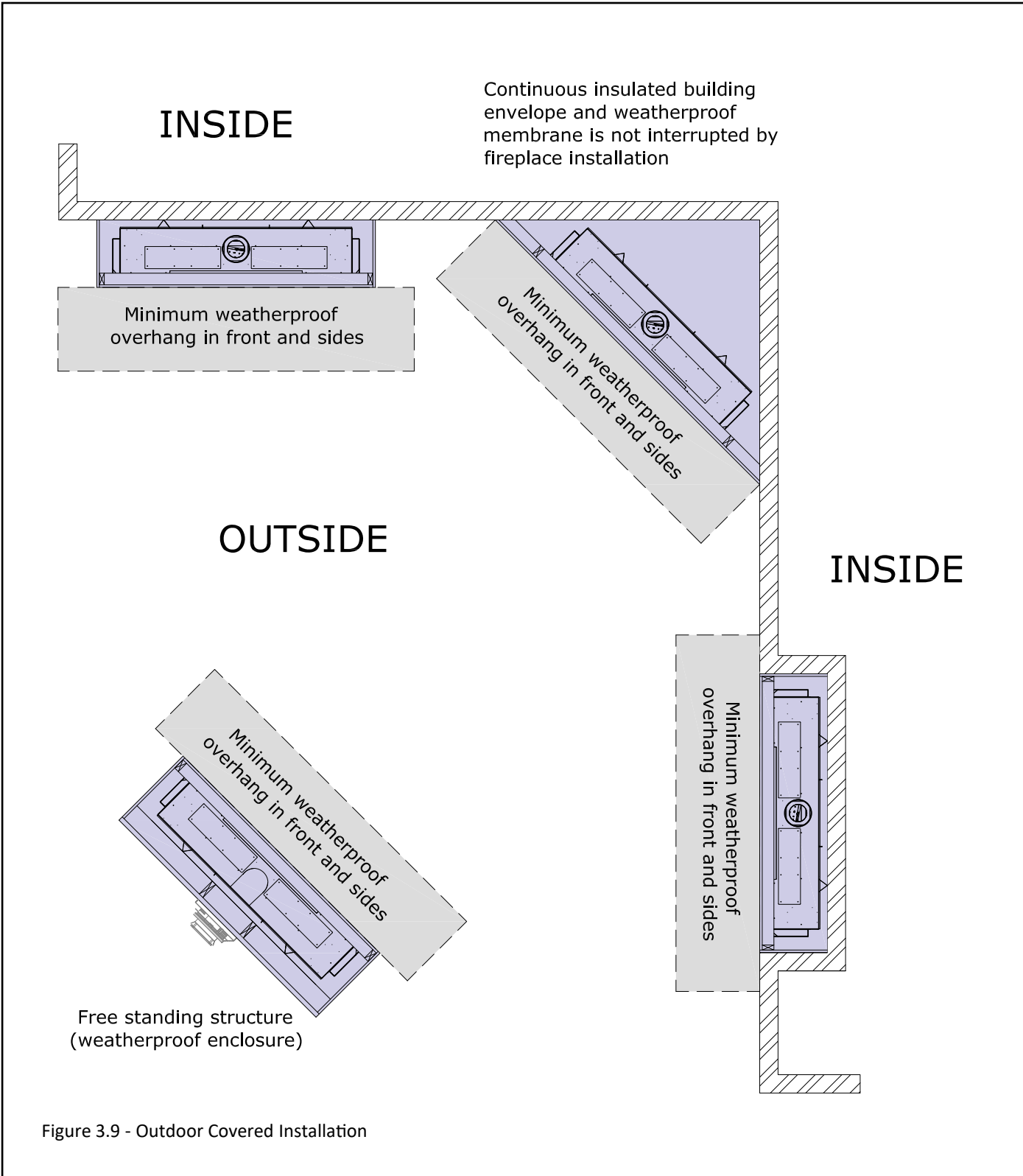

Figure 3.9 - Outdoor Covered Installation

## 4.0 Heat Management

The Komfort Zone Kit (KZK) offers the option to redistribute radiant heat through plenum(s). This option allows for combustible facing materials above the fireplace, heat reduction for a TV above the fireplace, and lower mantel clearances.

- If installing a Komfort Zone Kit (#KZK-062), the clearance to combustible requirements may be different than the standard dimensions listed in this section. Please reference the manual included with your kit before completing all fireplace framing and other installation considerations.

The Komfort Zone Kits have specific framing requirements, mantel requirements, and exterior trim dimensions.

- All minimum required dimensions must be maintained after all finishing materials are installed.
- The appliance cover plates and convection plates must be removed for Komfort Zone Kit installations, as shown in FIGURE 4.1 & Figure 4.3. KZK collars must be installed—See Figure 4.2.

### 4.1 Appliance Preparation for Komfort Zone Kit

#### Preparation Instructions

1. Remove the (16) sheet metal screws that secure the (2) cover plates at the top of the fireplace shown in Figure 4.1. Discard these two cover plates. Save the sheet metal screws for the next step.
2. Install the KZK collars that were provided with KZK-062 as shown in Figure 4.2. Reuse the sheet metal screws from the previous step.
3. Locate the (2) convection baffles as shown in Figure 4.3. There are (2) screws that secure each convection baffle. Remove the screws and convection baffles from the fireplace. Discard the screws and convection baffles.

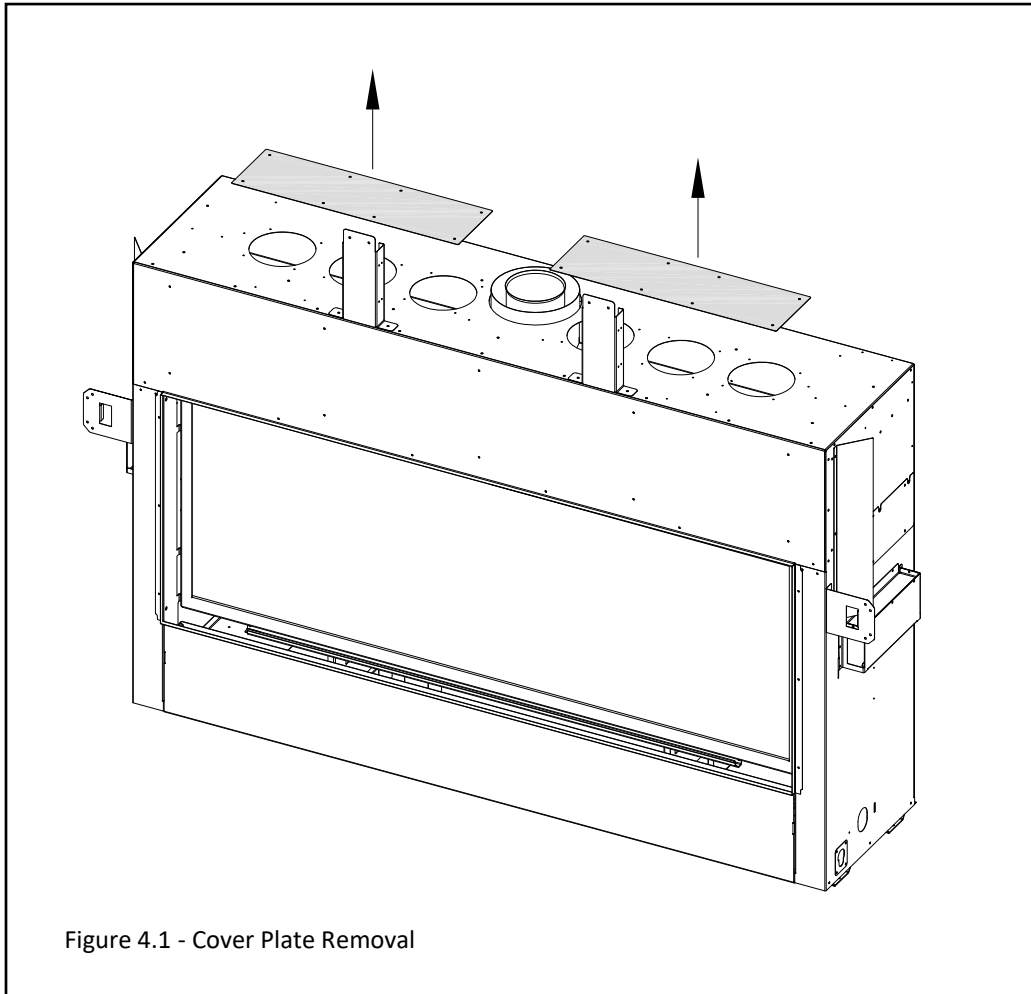

Figure 4.1 - Cover Plate Removal

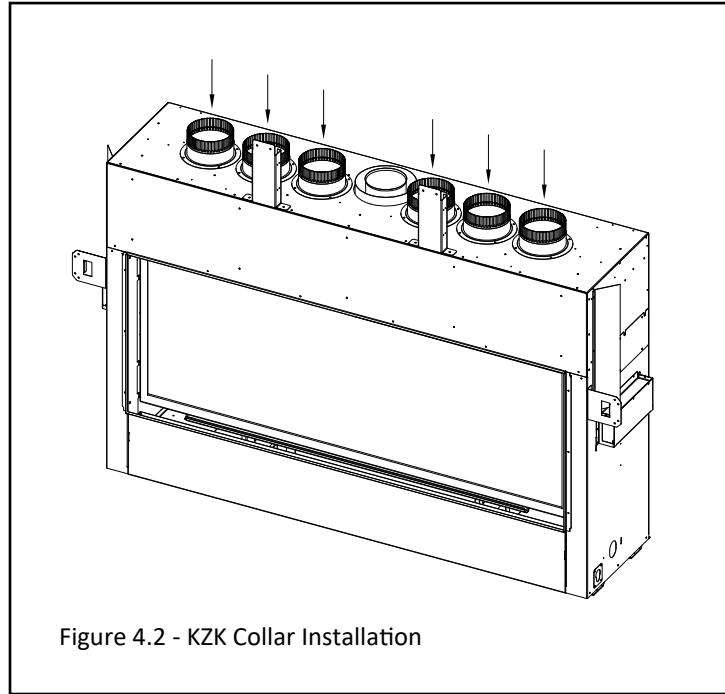

Figure 4.2 - KZK Collar Installation

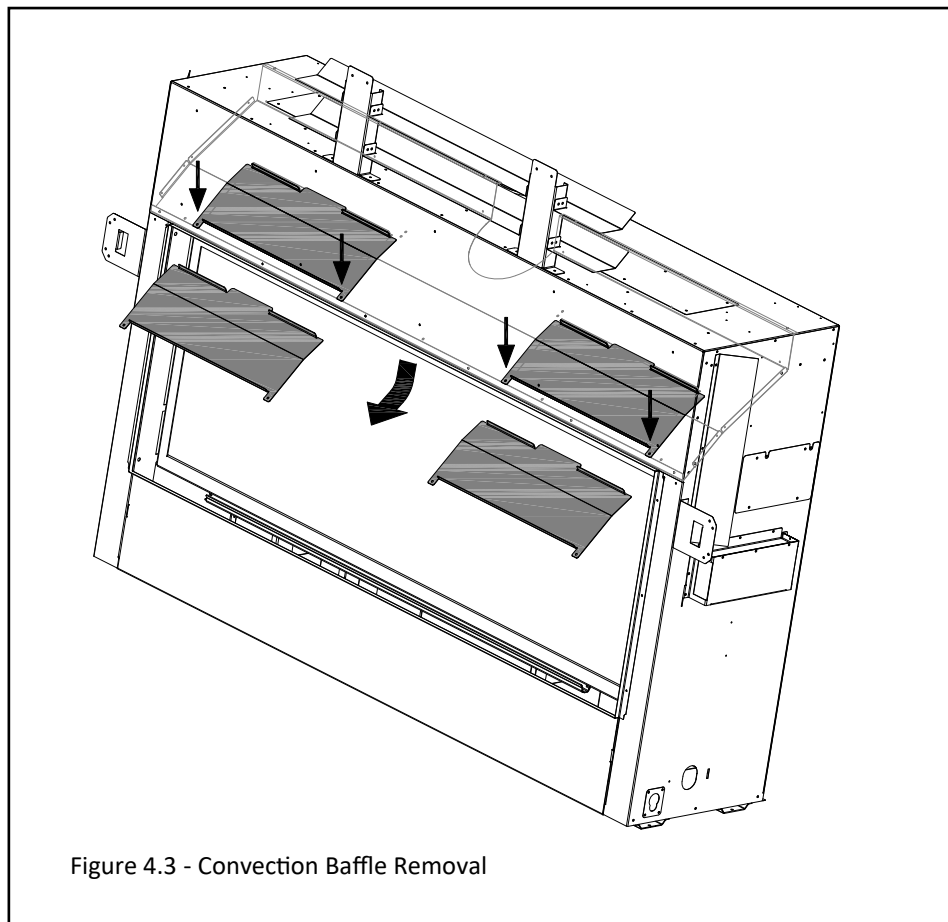

Figure 4.3 - Convection Baffle Removal



## 4.2 Appliance Preparation for an Interior or Exterior Heat Transfer Kit

### Preparation Instructions

1. Remove the (4) sheet metal screws that secure the HTK cover plate on the side of the appliance. Save these (4) sheet metal screws for later use.
2. Install the HTK air chute (Part # HTK-NTL) on the appliance as shown in Figure 4.4. Use the sheet metal screws saved from the previous step and the ones provided with the air chute for installation. Attach the collar on top of the air chute with the provided sheet metal screws.

Note: If you are using a HTK-EXT the damper stays in place. Make sure the damper rests on the unit and can move freely when airflow would be applied. The damper should lay flat on the fireplace as shown in Figure 4.5.

Note: If you are using the HTK-INT the damper must be removed. See Figure 4.6.

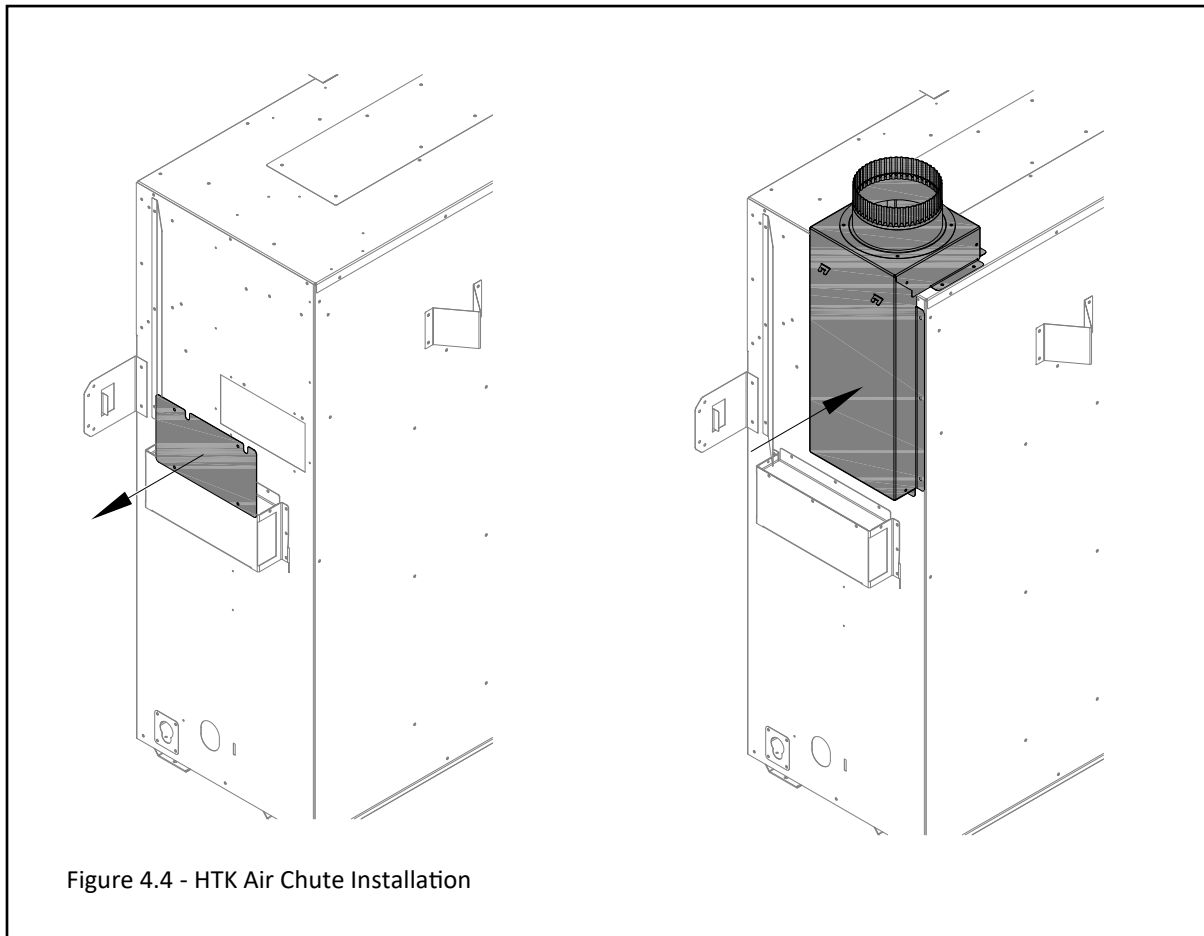
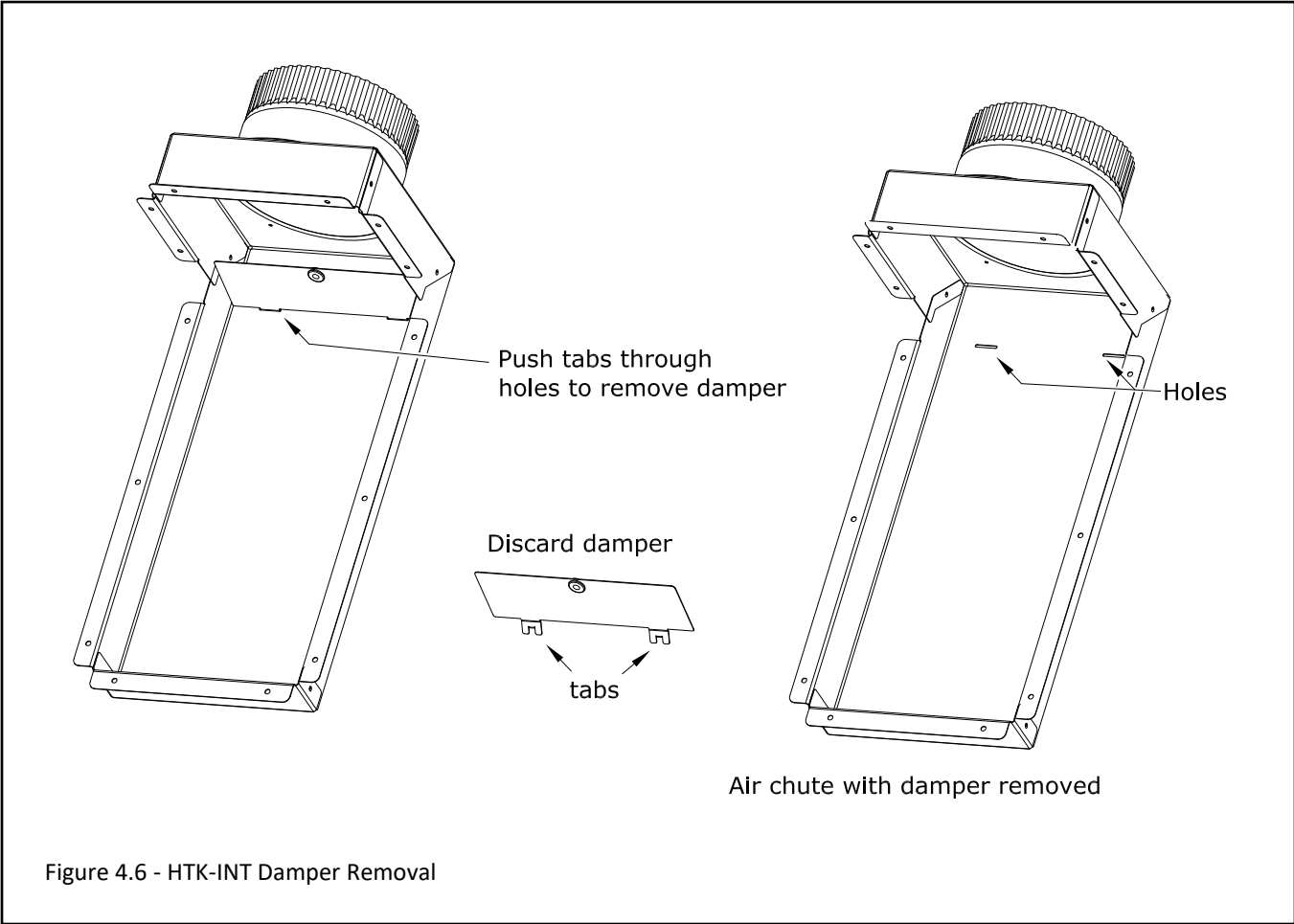
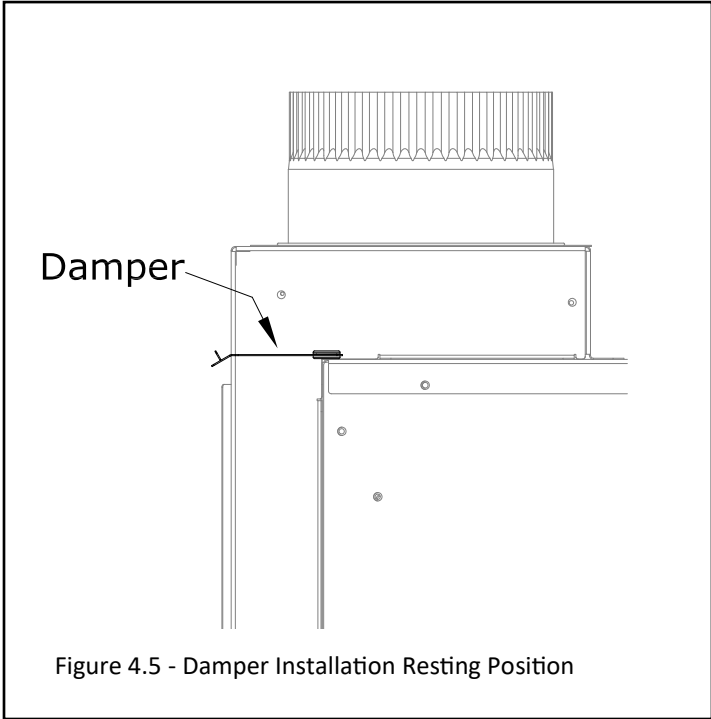

Figure 4.4 - HTK Air Chute Installation



# 5.0 Facing and Finishing

---

## 5.1 Standard Installation - Facing and Finishing Requirements

WARNING: Maintain all minimum clearances to combustibles from the appliance and vent system.

Utilizing the Kozy Power Vent system will not change mantel, hearth, sidewall, facing and finishing requirements from the standard design option.

Finishing material cannot obstruct ventilation air.

### 5.1.1 Combustible Hearth and Mantel Requirements

WARNING: All minimum clearances to combustible material MUST be maintained.

- **Combustible Mantel Projections:** As referenced in FIGURE 5.2 the 6" (152mm) mantel starts at 12" (305mm) above the top finishing edge. Mantel projections can increase 1" (25mm) of depth for every 1" (25mm) of height starting at the 6" (152mm) mantel.
- **Combustible Hearth:** Combustible hearth can have an unlimited projection. Hearth can be raised flush to the bottom finishing edge.
- **Mantel Leg:** Follow "Side Combustible Clearance" below. See FIGURE 5.5.
- **Combustible Sidewall Clearance:** the adjacent sidewall projection is unlimited and starts at 1" (25mm) from the side of the fireplace. See FIGURE 5.5.

### 5.1.2 Non-combustible Mantel or Surround Requirements

- **Noncombustible Mantel Projections:** As referenced in FIGURE 5.3, the 8" noncombustible mantel projection can start at 0" (0mm) from the top fireplace finishing edge. Follow projection 1" (25mm) up for every 1" (25mm) deeper.
- **Noncombustible Surround (top and sides of fireplace opening):** As referenced in FIGURE 5.4, the maximum of a 8" noncombustible surround can be installed flush at the side and top finishing edge of the fireplace.

### 5.1.3 Non-Combustible Zone

- See Figure 5.6, Non-Combustible Finishing Zone for the minimum requirement of noncombustible finishing material.
- Paper faced gypsum board, commonly known as drywall; including Type X Fire Rated board is not a non-combustible material. This material is not approved for use as a non-combustible material around the fireplace.
- WonderBoard brand boards are commonly used as a backerboard for tile. WonderBoard backerboard is not a non-combustible material and is not approved for use in the non-combustible material is required around the fireplace.
- Noncombustible facing and finishing materials must meet ASTM E 136.

### 5.1.4 Finishing Recommendations

NOTE: The surface area above the appliance may be affected by high temperatures emitted from this appliance. To help avoid or reduce the possibility of the sheetrock to crack, Hussong Mfg. recommends the following methods:

- Ensure the non-combustible material and sheetrock is dry and dust free.
- For taping and mudding seams, we recommend heat resilient tape, mesh and joint compounds, such as Durabond. Mud must be cured as per manufacturers recommendations.
- For a painted surface, use a high quality acrylic latex primer and finish coat. Avoid flat or light-colored paints to prevent discoloring.

Disclaimer: Kozy Heat does not guarantee any materials used around the fireplace. Kozy Heat disclaims any and all liability for any damage to finishing materials including warping, discoloring, cracking, peeling or flaking. This also includes any off-gassing or unpleasant smells from materials when they are heated.

### 5.1.5 Recommended Installation of Marble and other stone materials

Kozy Heat recommends the following statements when using marble, granite, or other stone finishing materials

- Never use a one-piece marble, granite or natural stone that is cut in a U-shape for finishing material to cover the sides and top areas around the fireplace opening.
- If you use a one piece U-shaped piece of marble, or stone finishing material the material is susceptible to cracking due to thermal expansion
- Refer to the manufacturer and supplier of your finishing material for use in high heat applications like around a fireplace. Ensure the material can be exposed to temperatures greater than 160°F. Kozy Heat does not assume any liability for discoloring, cracking, or other heat related damage.

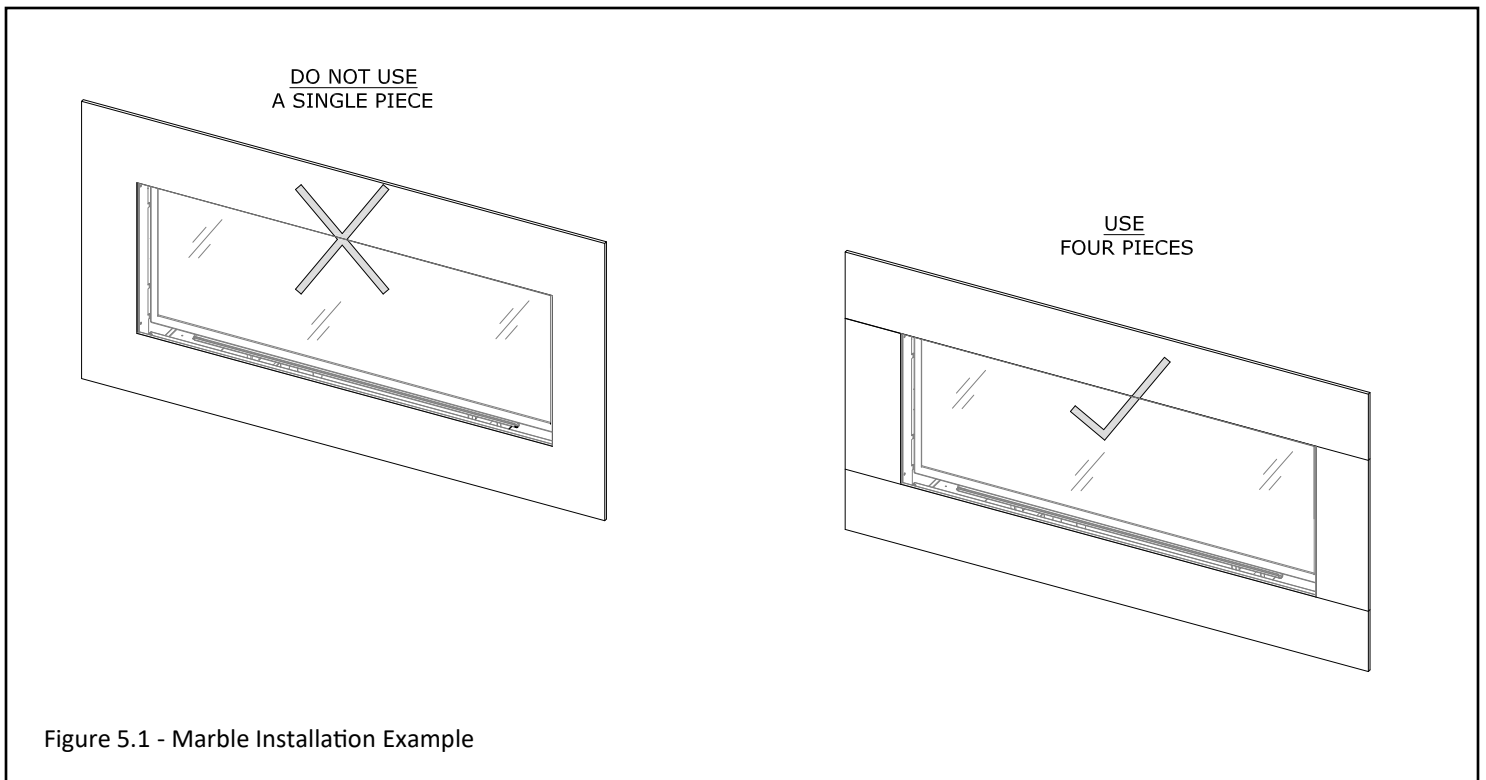

Figure 5.1 - Marble Installation Example

Figure 5.2 shows a 6" combustible mantel projection starting 12" up from the top finishing edge of the fireplace. The dimensions shown are allowed in standard installation scenario. Mantel projections can increase 1" (25mm) of depth for every 1" (25mm) of height starting at the 6" (152mm) mantel. A combustible hearth is allowed with unlimited projection starting flush at the bottom finishing edge of the fireplace.

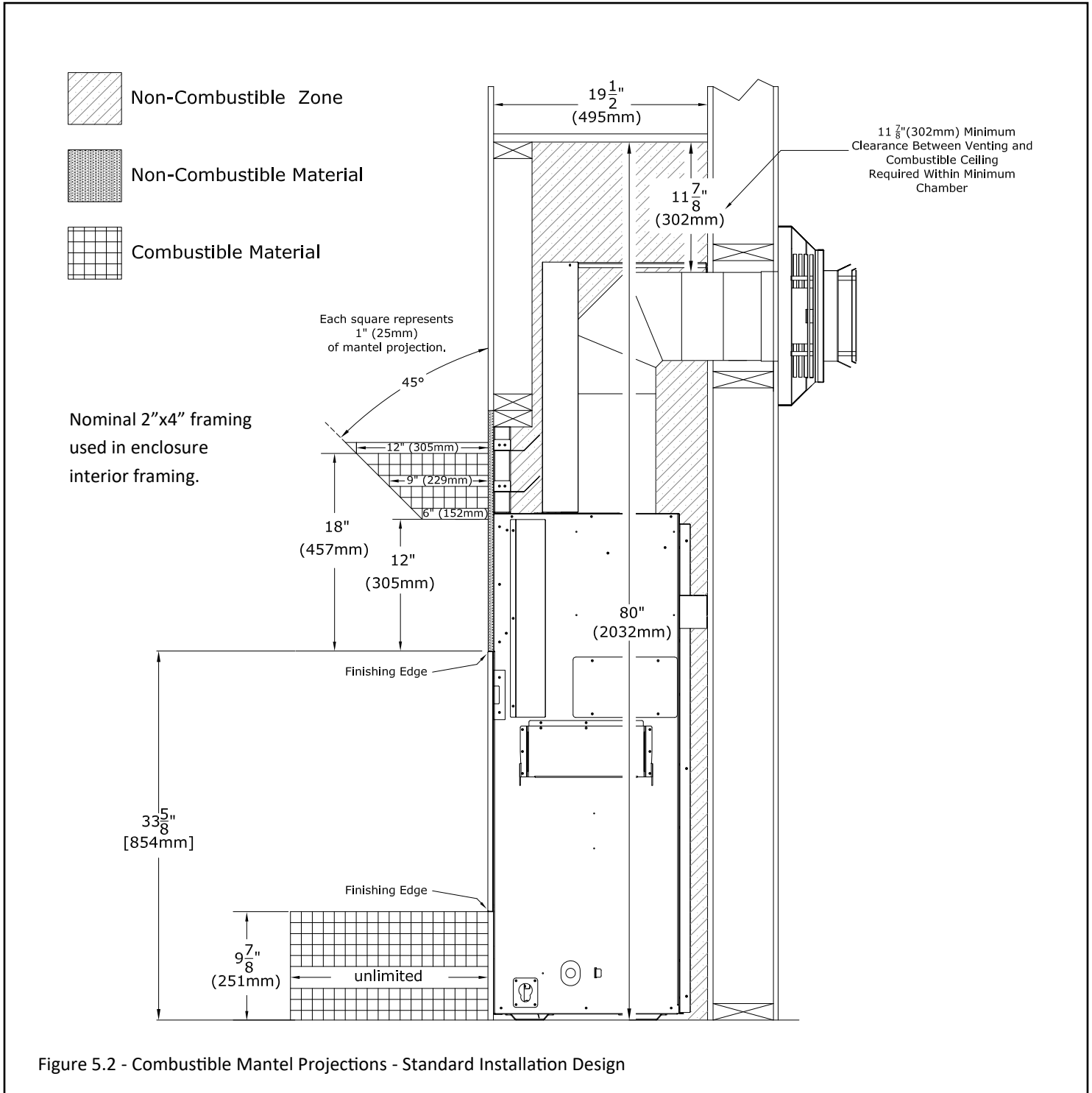

Figure 5.2 - Combustible Mantel Projections - Standard Installation Design

Figure 5.3 shows a 8" (203mm) non-combustible mantel projection flush with the top finishing edge of the fireplace. The dimensions shown are allowed in the standard installation scenario. Mantel projections can increase 1" (25mm) of depth for every 1" (25mm) of height starting at the 8" (203mm) mantel. A combustible hearth is allowed with unlimited projection starting flush at the bottom finishing edge of the fireplace.

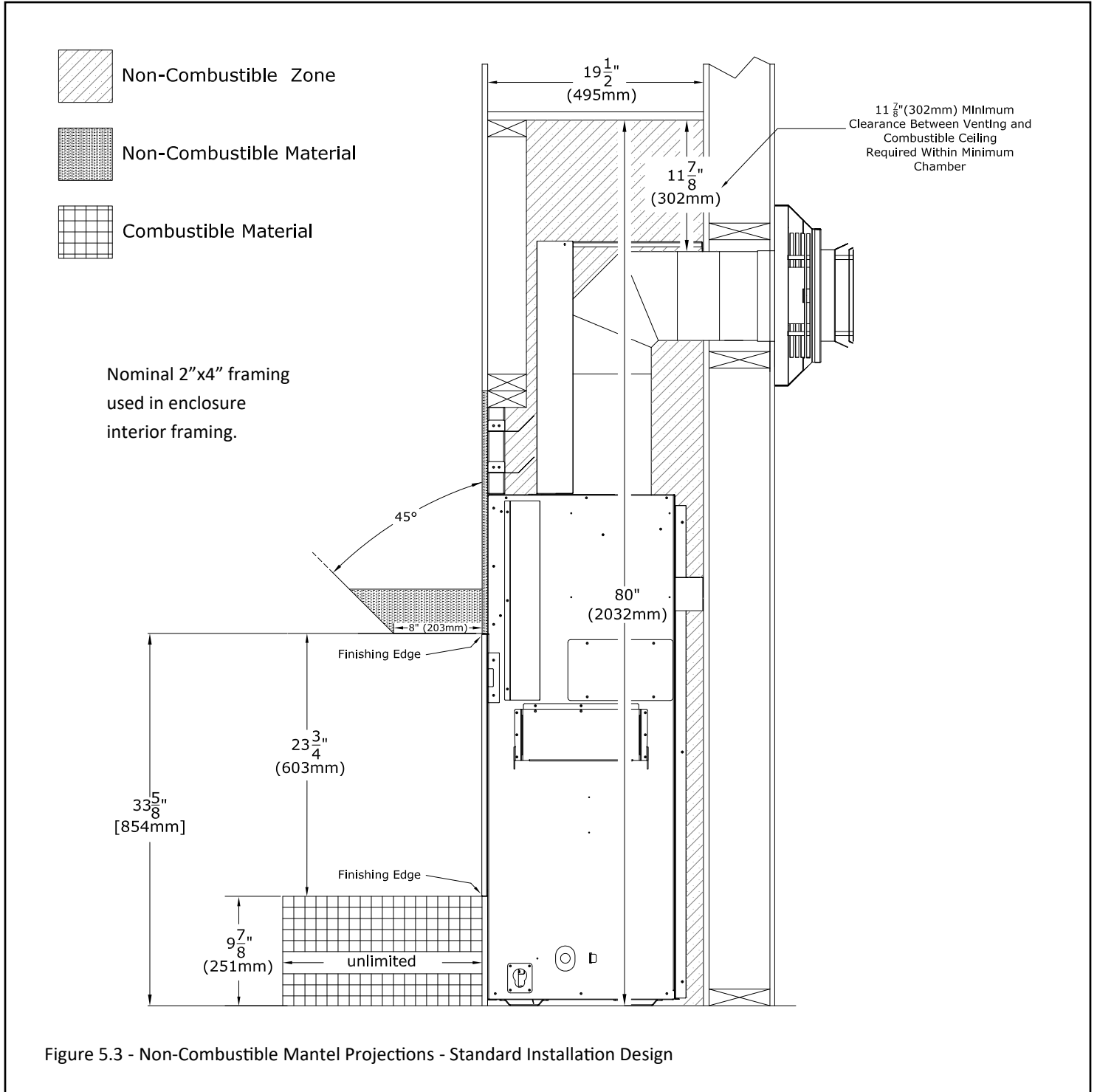

Figure 5.3 - Non-Combustible Mantel Projections - Standard Installation Design

Figure 5.4 shows a maximum of a 8" non-combustible surround is allowed 0" (0mm) from the fireplace finishing edge. The horizontal and vertical dimension of the surround is unlimited. Figure 5.4 shows the allowance of an unlimited hearth extension

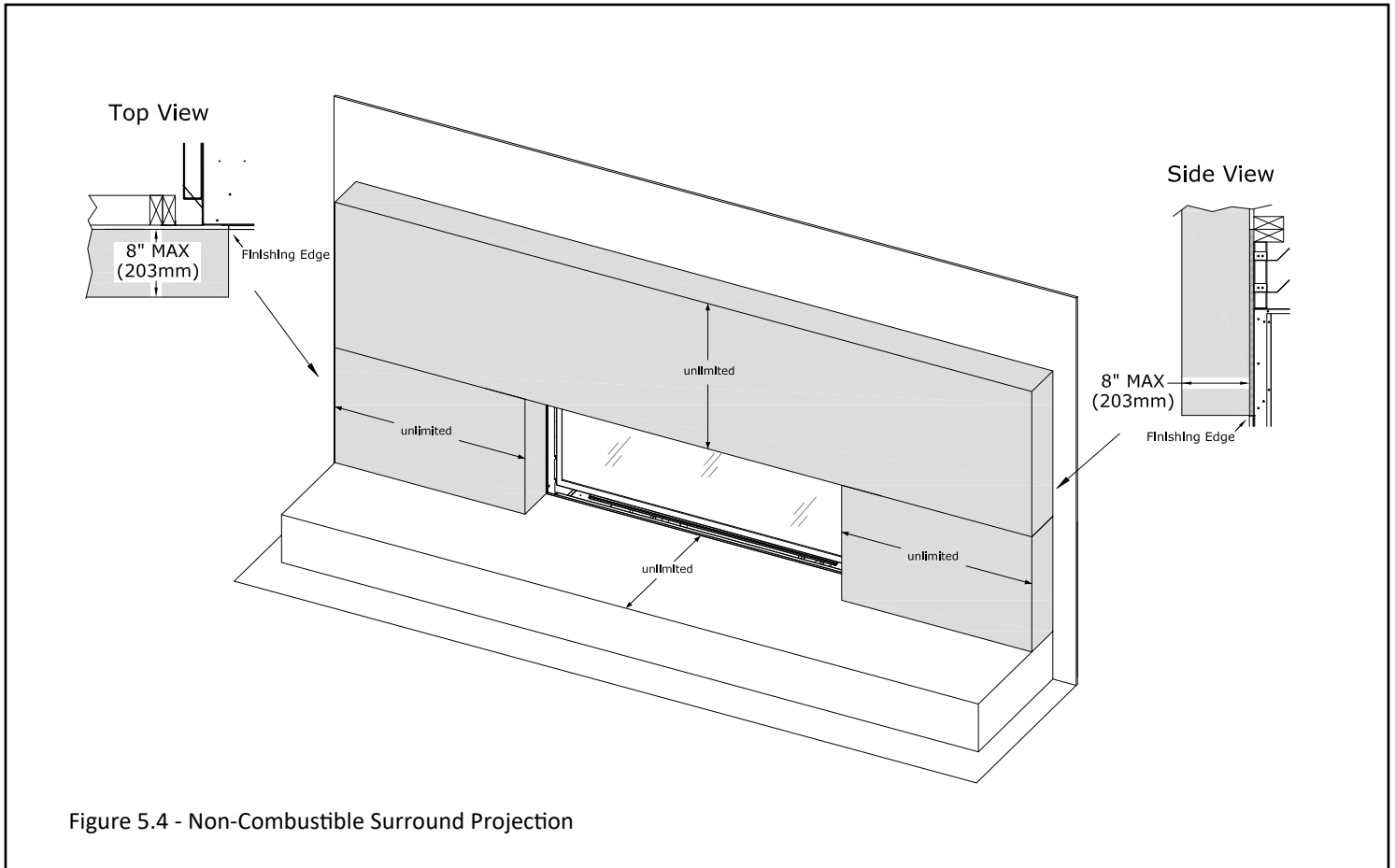

Figure 5.4 - Non-Combustible Surround Projection

Figure 5.5 shows a combustible sidewall flush with the side finishing edge of the fireplace. The combustible sidewall is allowed to be unlimited. If you are using the optional NK60TL-RS Rectangle Surround (Section 5.2) provide the necessary clearance to sidewall.

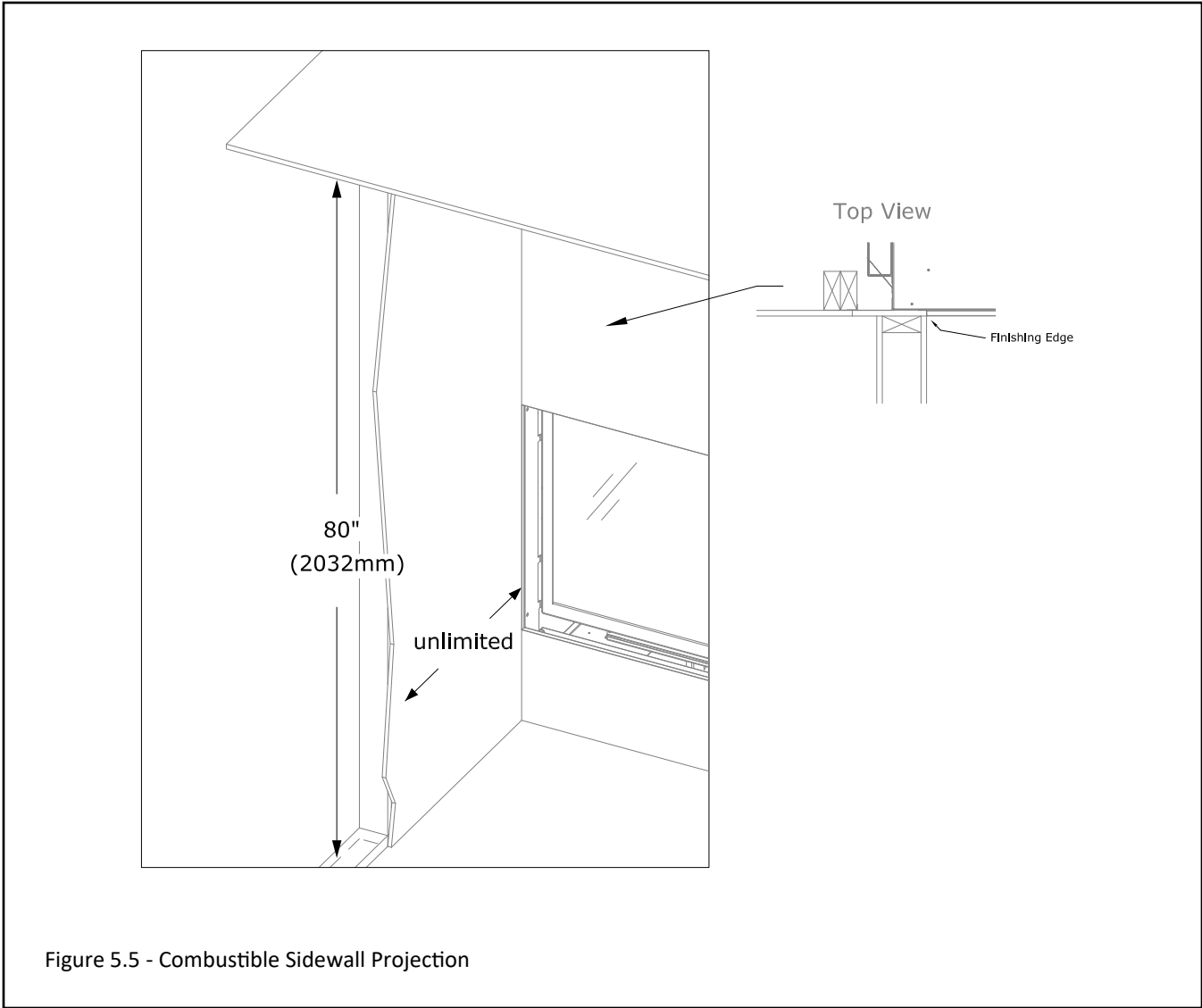
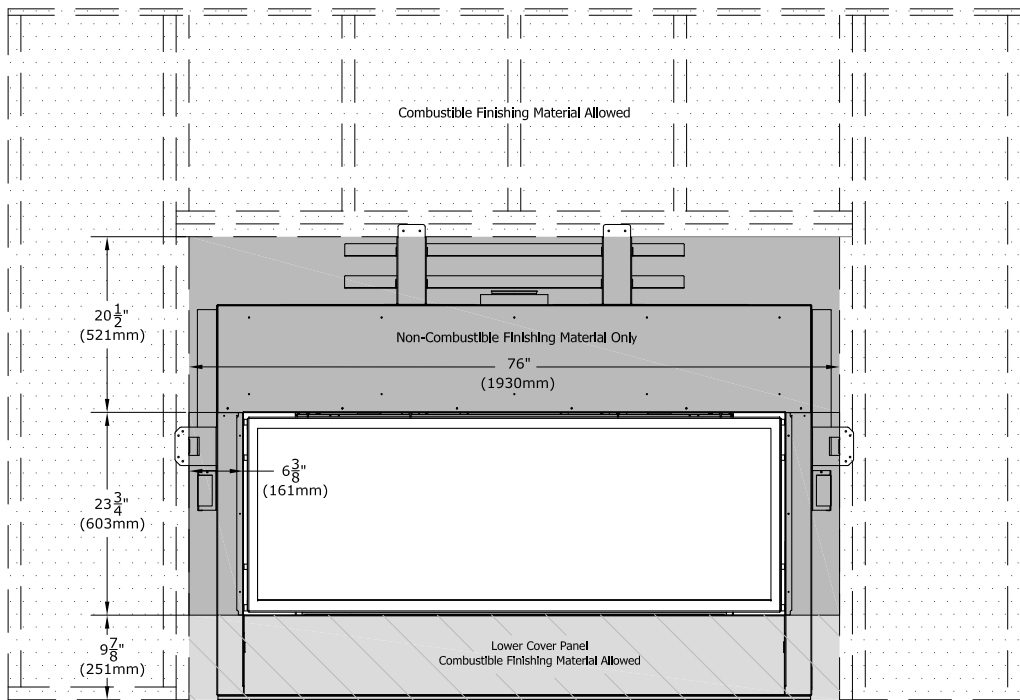

Figure 5.5 - Combustible Sidewall Projection





Non-combustible finishing material only
  Combustible finishing material allowed
  Combustible finishing material allowed. See image below for acceptable screw locations

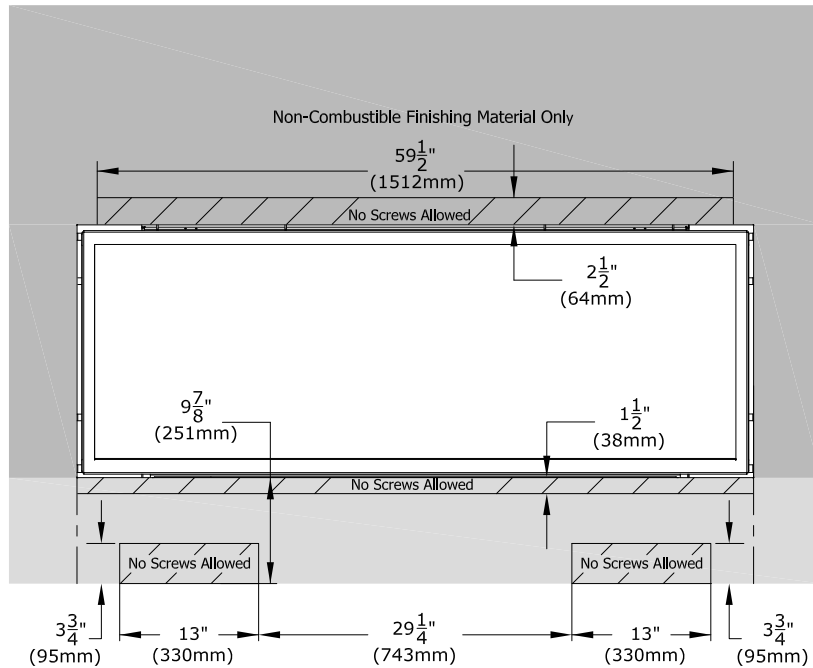

Figure 5.6 - Non-Combustible Finishing Material Requirements

## 5.2 Rectangle Surround Installation

The rectangle surround (#NK60TL-RS) is an optional accessory for this fireplace. The purpose of this surround is to cover the edge of finishing material where it meets the finishing edge along all 4 sides of the fireplace opening.

The rectangle surround accommodates up to 1-5/8" (41mm) finishing material. This dimension includes the required noncombustible facing material.

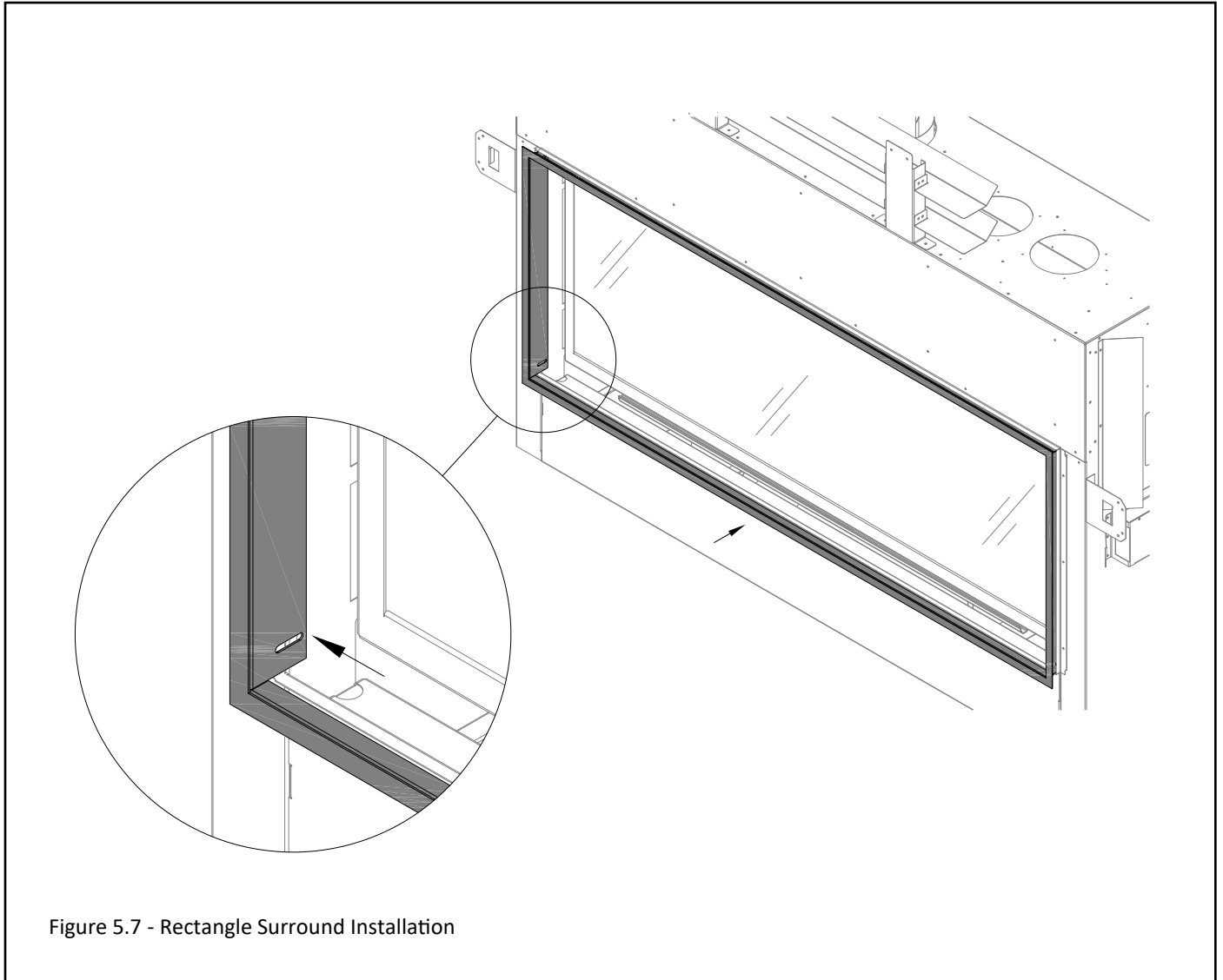

Figure 5.7 - Rectangle Surround Installation

### 5.3 Safety Barrier Installation

**Note: A barrier designed to reduce the risk of burns from the hot viewing glass is provided with this appliance and shall be installed for the protection of children and other at-risk individuals**

- If the barrier becomes damaged, the barrier shall be replaced with the manufacturer’s barrier for this appliance
- Clothing or other flammable material should not be placed on or near the appliance
- Any safety screen, guard, or barrier removed for servicing an appliance must be replaced prior to operating the appliance

**Installation:**

The safety barrier has two mounting hooks on each side of the screen barrier. There are slots on each side of the fireplace located between the glass frame and the side finishing edge. Align the mounting hook to the slot on each side of the fireplace and lift up the safety screen barrier and push towards the fireplace so the mounting hooks latch around the glass frame. You can tell that the safety barrier is correctly seated if there is even spacing between the screen barrier and finishing edge on all four sides.

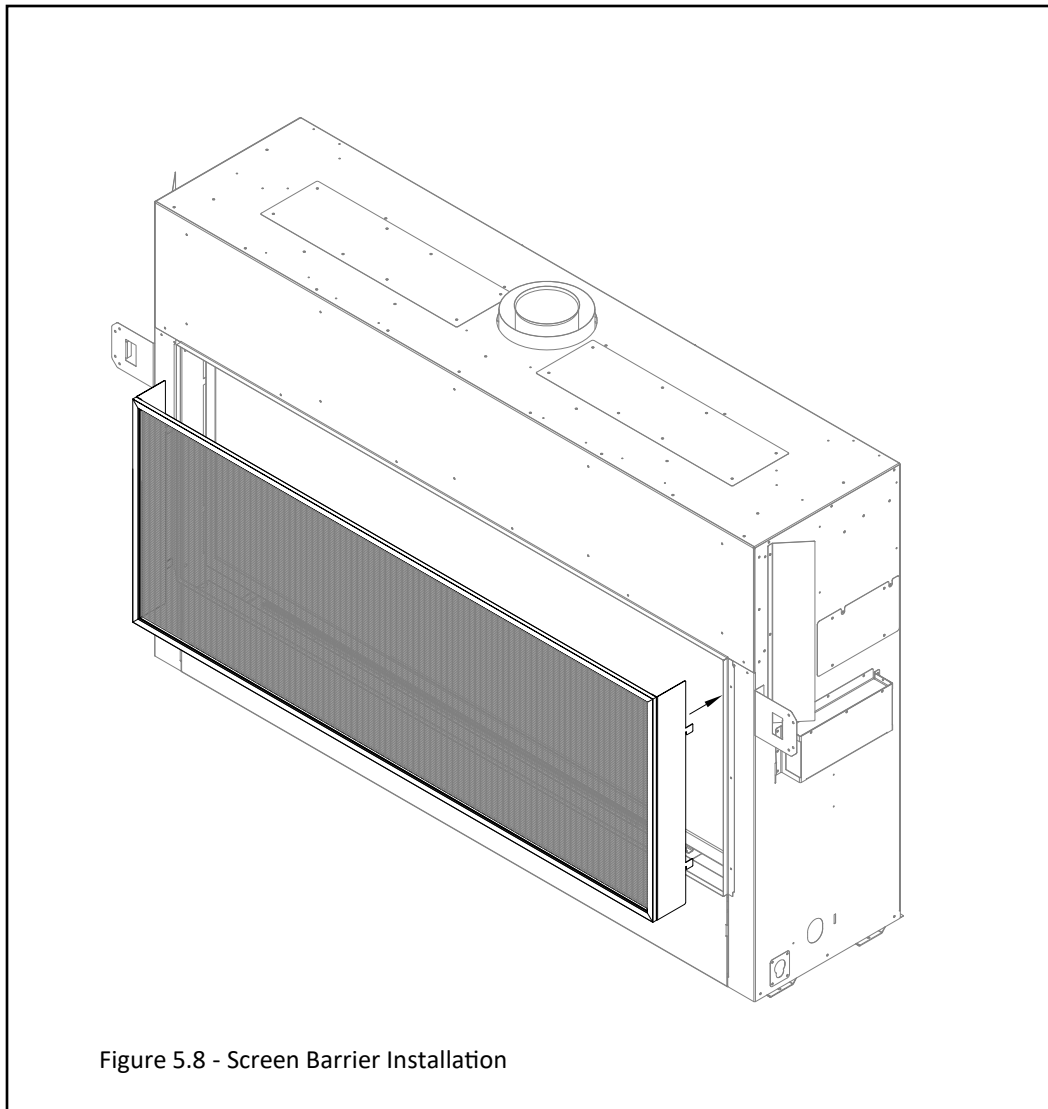

Figure 5.8 - Screen Barrier Installation

# 6.0 Gas Line Connection

## 6.1 Gas Conversion

Note: Stepper Motor sold separately to complete gas conversion

ATTENTION: The conversion shall be carried out in accordance with the requirements of the provincial authorities having jurisdiction and in accordance with the requirements of the ANSI Z223.1 installation code.

This fireplace is manufactured for use with natural gas. Follow the instructions included with the conversion kit if converting to propane.

## 6.2 Gas Line Installation

CAUTION: Installation of the gas line must only be done by a qualified person in accordance with local building codes, if any. If not, follow ANSI Z23.1. Commonwealth of Massachusetts installations must be done by a licensed plumber or gas fitter.

NOTE: The appliance and its individual shutoff valve must be disconnected from the gas supply piping system during any pressure testing of that system at pressures in excess of ½ psi (3.5 kPa). For test pressures equal to or less than ½ psi (3.5 kPa), the appliance must be isolated from the gas supply piping system by closing its individual manual shut-off valve.

- A listed (and Commonwealth of Massachusetts approved) ½" (13mm) tee handle manual shut-off valve and flexible gas connector are to be connected to the ½"(13mm) control valve inlet. If substituting for these components, please consult local codes for compliance.
- This fireplace is equipped with a 3/8" (10mm) x 18" (457mm) long flexible gas connector and manual shut-off valve.
- Run gas line into fireplace through gas line hole provided. The gas line should be run to the point of connection where the shut-off valve and flexible gas line will connect. See Figure 2.1, Appliance Dimensions for gas line access.
- Do not run gas line in a manner that would obstruct fan operation.
- For high altitude installations, consult the local gas distributor or the authority having jurisdiction for proper rating methods.

	Natural Gas	Propane
Minimum Pressure	5" WC (1.25kPa) 7" WC (1.74 kPa) recommended	11" WC (2.74 kPa)
Maximum Pressure	10" WC (2.49 kPa)	13" WC (3.24 kPa)

# 7.0 Termination Locations

## 7.1 Vertical Vent Cap Termination

WARNING: This gas appliance must not be connected to a chimney flue serving a separate solid-fuel burning appliance.

Note: Natural Draft Applications only.

- Refer to Figure 7.1 below for vertical vent terminations clearances.
- Refer to Figure 7.2 below for clearance between two vertical terminations.

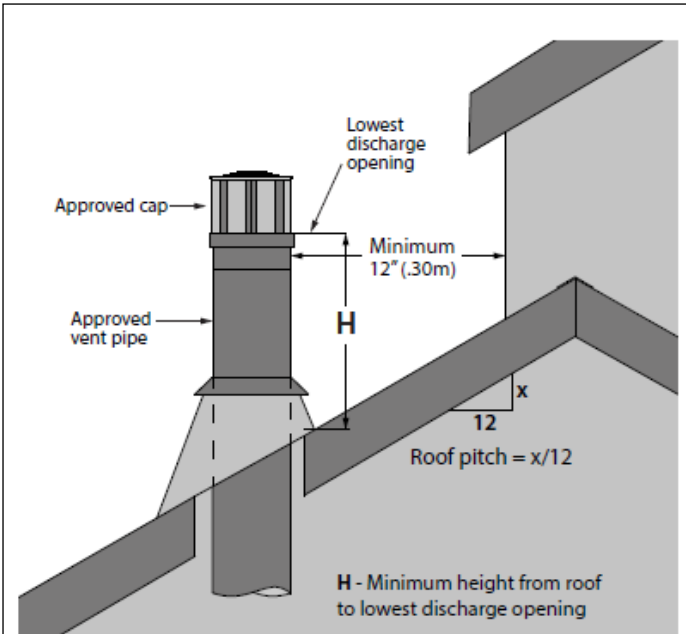

H - Minimum height from roof to lowest discharge opening

Clearance between two vertical terminations for US and Canadian installations (may be the same height)

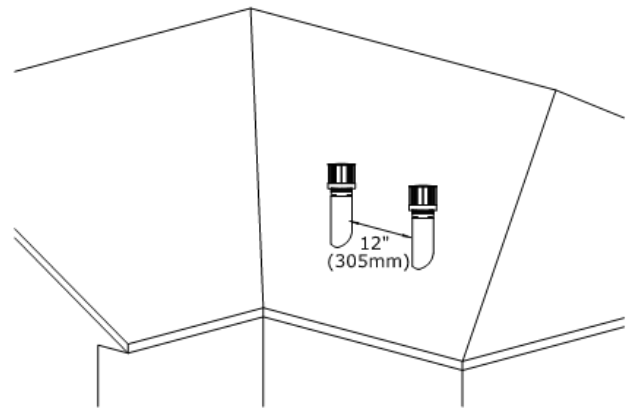

Figure 7.2 - Clearances Between Two Terminations

Roof Pitch	Minimum height (H) from roof	
	Feet	Meters
Flat to 6/12	1.0	0.30
Over 6/12 to 7/12	1.25	0.38
Over 7/12 to 8/12	1.5	0.46
Over 8/12 to 9/12	2.0	0.61
Over 9/12 to 10/12	2.5	0.76
Over 10/12 to 11/12	3.25	0.99
Over 11/12 to 12/12	4.0	1.22
Over 12/12 to 14/12	5.0	1.52
Over 14/12 to 16/12	6.0	1.83
Over 16/12 to 18/12	7.0	2.13
Over 18/12 to 20/12	7.5	2.27
Over 20/12 to 21/12	8.0	2.44

Figure 7.1 - Vertical Vent Clearances

## 7.2 Minimum Termination Clearances

Refer to Figure 7.3 and the table below for natural draft vent termination clearance locations.

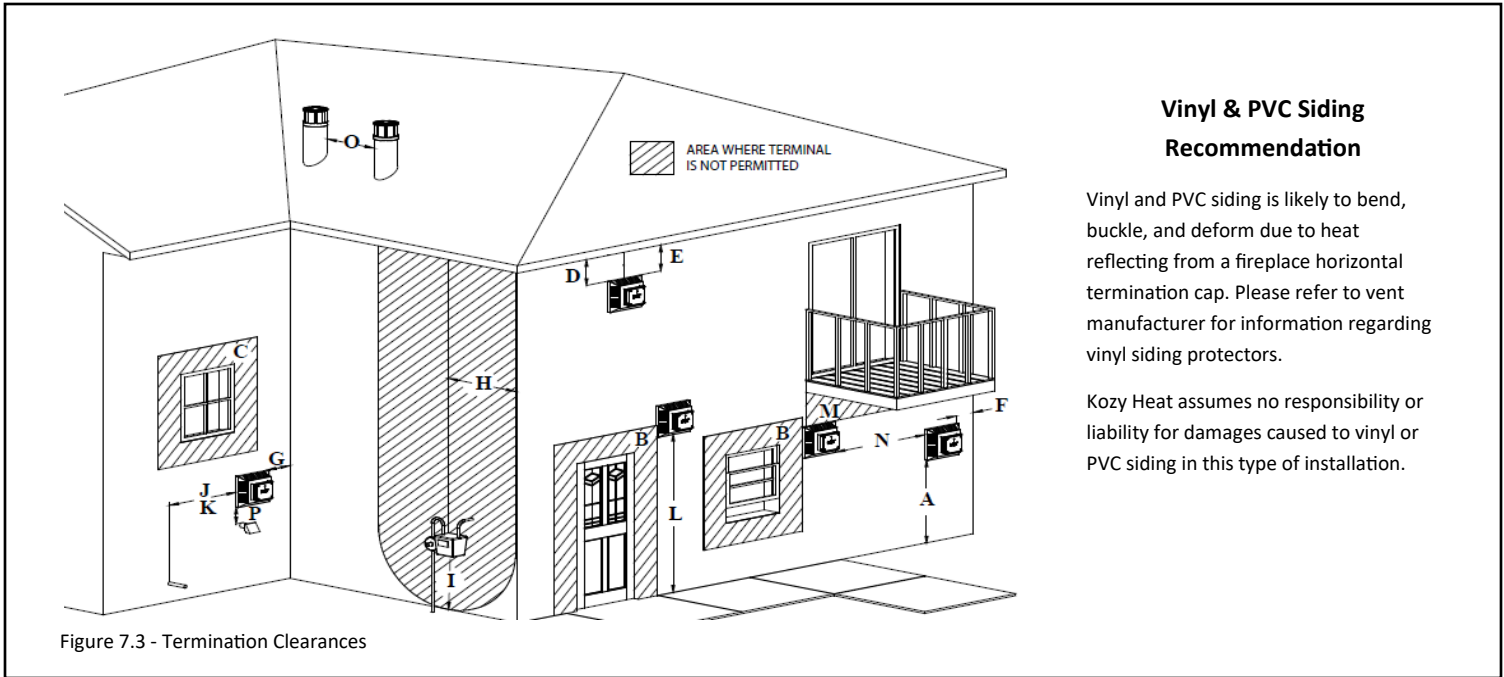

		Canadian Installations	US Installations
A	Clearance above grade, veranda, porch, desk, or balcony.	12" (30cm)	12" (30cm)
B	Clearance to window or door that may be opened	12" (30cm)	9" (23cm)
C	Clearance to permanently closed window (recommended to prevent condensation on window)	12" (30cm)*	12" (30cm)*
D	Vertical clearance to ventilated soffit located above the terminal within a horizontal distance of 2 feet (61cm) from the edge of the terminal	24" (61cm)*	24" (61cm)*
E	Clearance to unventilated soffit	12" (30cm)*	12" (30cm)*
F	Clearance to outside corner	0" (0cm)*	0" (0cm)*
G	Clearance to inside corner	3" (8cm)*	3" (8cm)
H	Clearance to each side of center line extended above meter/regulator assembly	3' (91cm) within a height 15' (4.5m) above the meter/regulator assembly	*
I	Clearance to service regulator vent outlet	3' (91cm)	*
J	Clearance to non-mechanical air supply inlet to building or the combustion air inlet to any other appliance	12" (30cm)	9" (23cm)
K	Clearance to mechanical air supply inlet	6' (1.83m)	3' (91cm) above **
L	Clearance above paved sidewalk or paved driveway located on public property	7' (2.13m)†	*
M	Clearance under veranda, porch deck, or balcony	12" (30cm)‡	12" (30cm)
N	Clearance between two horizontal terminations	12" (30cm)	12" (30cm)
O	Clearance between two vertical terminations (may be same height)	12" (30cm)	12" (30cm)
P	Above furnace exhaust or inlet	12" (30cm)	12" (30cm)
* Clearance in accordance with local installation codes and the requirements of the gas supplier			
** Massachusetts: 10' (3m) above] if within 10' (3m) horizontally			
†A vent shall not terminate directly above a sidewalk or paved driveway that is located between two single family dwellings and serves both dwellings.			
‡ Permitted only if veranda, porch, desk, or balcony is fully open on a minimum of two sides beneath the floor			
VINYL SOFFIT, VINYL CEILING, AND VINYL OVERHANG DISCLAIMER: Clearances to heat resistant material (i.e. wood, metal). This does not include vinyl. Hussong Manufacturing Co., Inc. will not be held responsible for heat damage caused from terminating under vinyl overhangs, vinyl ceilings, or vinyl ventilated/unventilated soffits.			

# 8.0 Venting

## 8.1 Approved Vent Systems

This appliance is equipped for use with a 5" (127mm) exhaust by 8" (203mm) air intake co-axial vent pipe system.

***This appliance is approved for use with Kozy Heat Power Vent System #KPV (sold separately). Power Vent configurations and requirements are located in the #KPV manual.***

This appliance is approved for use with manufacturers (horizontal and vertical terminations): American Metal Products (Ameri-Vent), BDM, ICC, Metal Fab., Selkirk, and Simpson DuraVent. See sections 8.1.1 and 8.1.2.

This appliance can be adapted to use 4" diameter aluminum flexible pipe by any listed vent manufacturer when used in combination with an existing minimum 7" ID Class A metal/masonry chimney. Refer to section 8.6 for more information.

Refer to the vent manufacturer's installation manual for complete installation instructions. Installation must conform with the requirements and restrictions specified in this manual.

### 8.1.1 Approved 5" x 8" Vent Systems

Table 8.1, Approved 5" x 8" Vent Systems	
Vent Manufacturer	Vent Cap Part Number
American Metal Products (Ameri-Vent)	5DHCS
	5DHC
	5DVC
	5D36S
BDM	DVR8-HCP
	DVR8-HC
	DVR8-VCLP
	DVR8-SNK14
	DVR8-SNK36
Simpson DuraVent	58DVA-HC
	58DVA-HRCS
	58DVA-HSCH
	58DVA-VCH
	58DVA-VC
	58DVA-VCS
ICC	TM-5HT
	TM-5RHT
	TM-5ST36
Metal Fab	5DHT
	5DST14
	5DST36
Selkirk	5DT-HC
	5DT-VT
	5DT-VC

### 8.1.2 Approved 4" x 6-5/8" Vent Systems

This appliance may be reduced from a 5" x 8" to a 4" x 6-5/8" vent system using a vent reducer from an approved vent system. Refer to the vent pipe manufacturer's installation manual for more information.

**Note: Vertical terminations only for reduced 4" x 6-5/8" venting**

Table 8.2, Approved 4" x 6-5/8" Vent Systems	
Vent Manufacturer	Vent Cap Part Number
American Metal Products (Ameri-Vent)	4DVC
BDM	DVR6-VCLP
Kozy Heat	KPV
Simpson DuraVent	46DVA-VCH
	46DVA-VC
	46DVA-VCE
Selkirk	4DT-VT
	4DT-VC

## 8.2 Venting Requirements

NOTE: Consult the local and national installation codes to assure adequate combustion and ventilation air is available. Venting requirements apply to both natural gas and propane.

- Flame height and appearance will vary depending upon venting configuration and the type of fuel used.
- Provide a means for visually checking the vent connection to the appliance after the fireplace is installed.
- A minimum of 1" (25mm) clearance on all sides of the vertical vent pipe must be maintained. Attic insulation shields may be insulated using unfaced insulation products listed as noncombustible per ASTM E 136.
- A minimum of 1" (25mm) clearance on the top, sides, and bottom of the horizontal vent pipe must be maintained. Wall thimble products that comply with the required clearances to combustibles must be installed for all horizontal vent runs that pass through interior or exterior walls. These wall thimble products may be insulated using unfaced insulation products listed as noncombustible per ASTM E 136.
- The provided vent heat shield is required to be installed in all venting scenarios. See Figure 8.1. The stand off assembly and heat shields are cut away in this image to show the vent heat shield better.
- The gas appliance cannot be connected to a chimney flue that is serving a separate solid-fuel burning appliance.
- Horizontal vent sections require at least 1/4" (6mm) rise for every 12" (305mm) of travel.

## 8.3 Vent Restriction

- Burner flame appearance and characteristics are affected by altitude, fuel quality, venting configuration, and other factors. To achieve desirable flame appearance, the vent exhaust may be restricted by the restrictor plate (included in components packet).
- The restrictor plate is shipped with all inner rings intact, and when installed, provides the most vent restriction. There are (2) inner rings that can be knocked out. As you knock out and remove an inner ring you have less vent restriction where removing both inner rings you will have the least amount of vent restriction.
- Follow FIGURE 8.1 for restrictor plate installation before attaching venting or through the baffle if venting is already attached. For vent restriction plate recommendations and adjustments, see section 12.2.3, Vent Restriction (after installation).

## 8.4 Use of Flexible Venting Outside the Appliance Enclosure

- If an approved venting manufacturer offers flexible venting options that can replace rigid vent pipe follow the vent manufacturer's instructions.
- Flexible vent pipe can only be used outside of the appliance enclosure.
- Flexible vent pipe cannot be used to terminate the vent system horizontally or vertically.

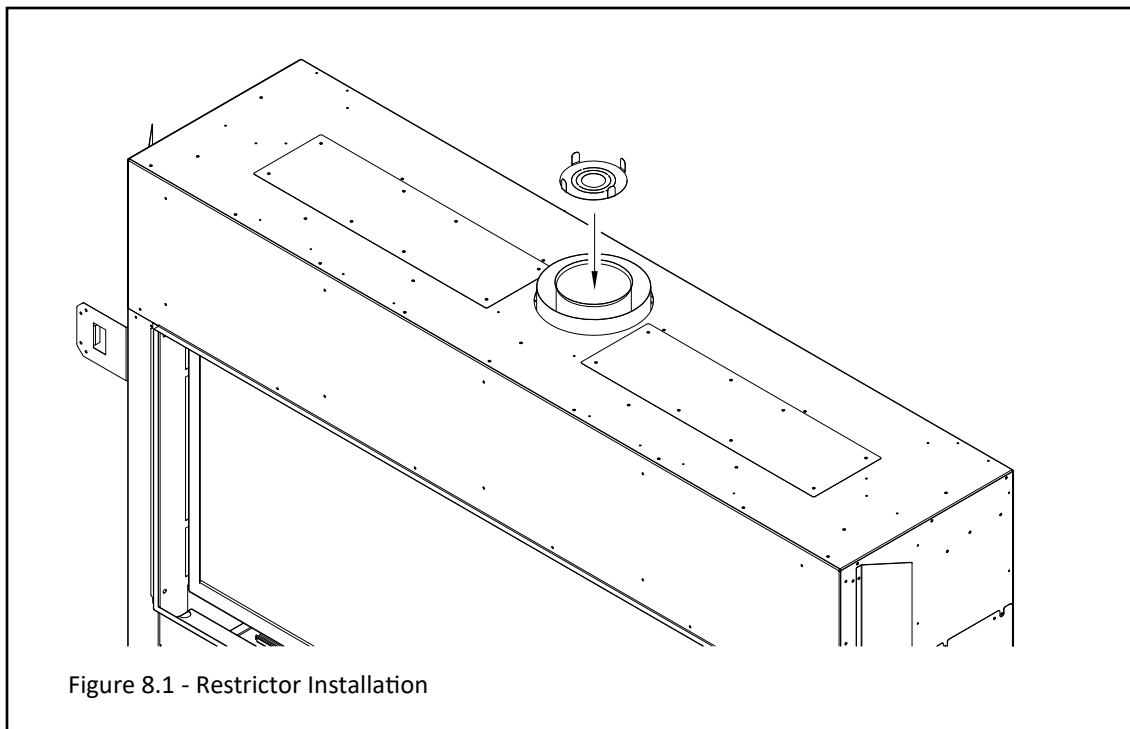

Figure 8.1 - Restrictor Installation



## 8.5 Natural Draft Co-Axial Pipe Installations

### 8.5.1 Vertical Terminations

Note: Natural Gas and Propane Installations

- (i) Minimum / Maximum Vertical Terminations:  
3' (914mm) minimum vertical length / 50' (15.24m)  
maximum vertical length + termination cap

- (ii) Minimum / Maximum Vertical Terminations with Reducer\*:  
4" x 6-5/8" reducer + 3' (914mm) minimum vertical  
length / 50' (15.24m) maximum vertical length +  
termination cap

To use any 45° elbow for vertical terminations with a reducer, the total minimum vertical vent run must be 10' (3.05m). A total of (4) 45° elbows may be used. No 90° elbows are allowed. For every 45° elbow used, 18" (457mm) must be subtracted from maximum venting allowed.

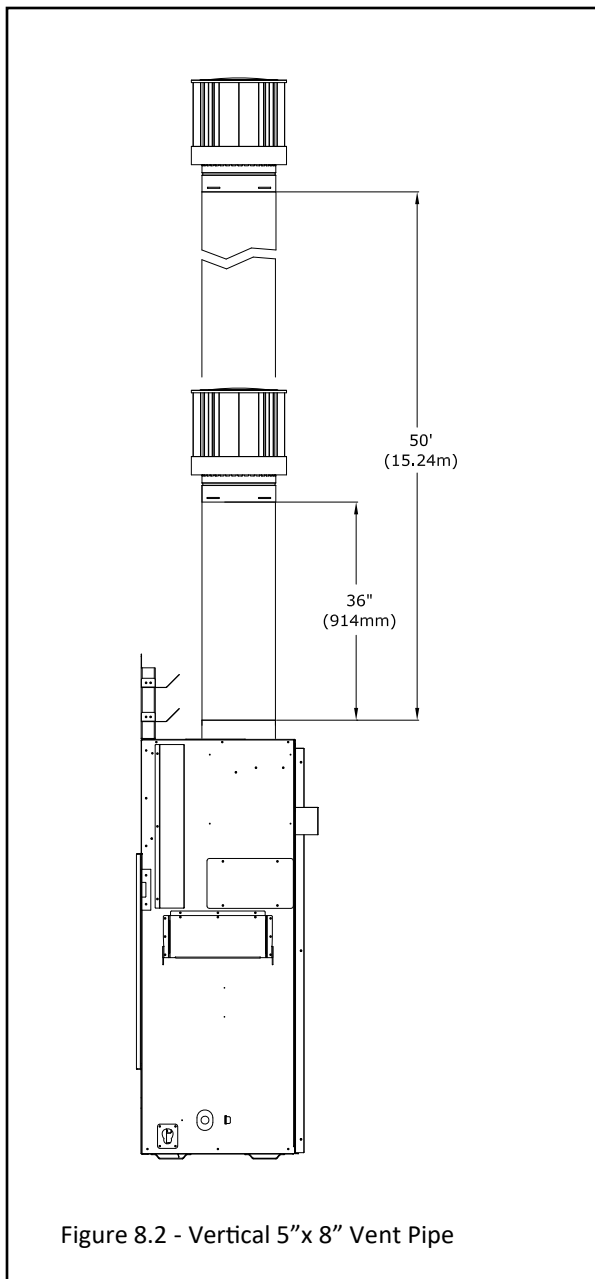

Figure 8.2 - Vertical 5"x 8" Vent Pipe

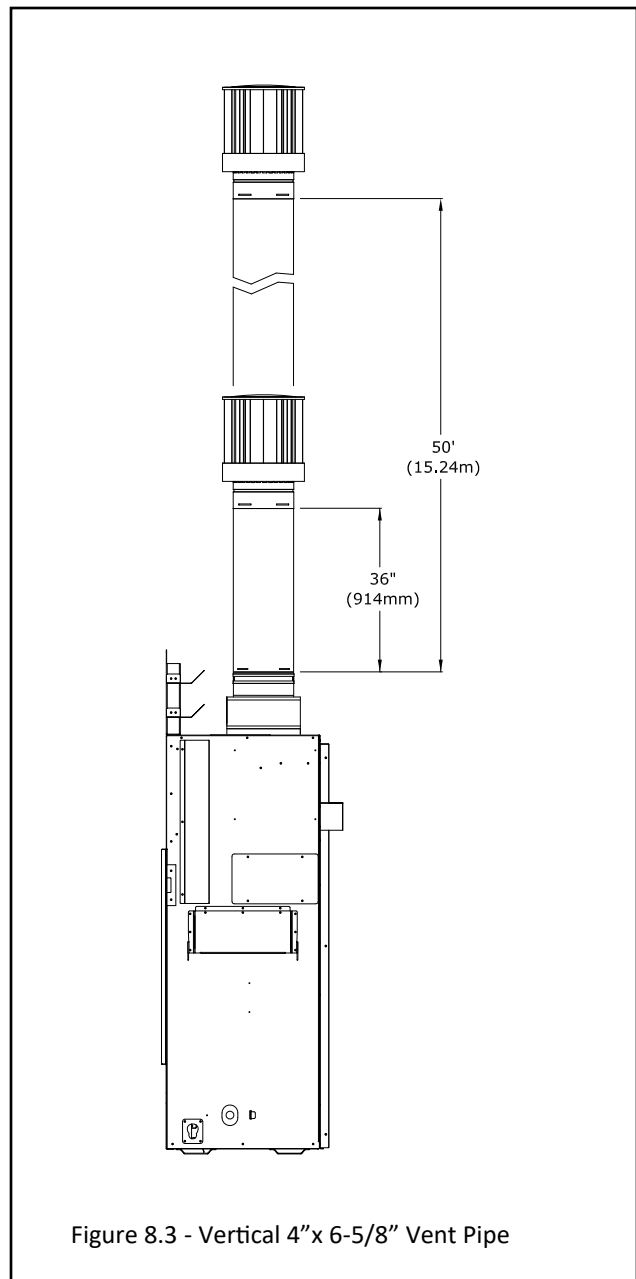

Figure 8.3 - Vertical 4"x 6-5/8" Vent Pipe

## 8.5.2 Horizontal Terminations

Note: Natural Gas and Propane Installations

IMPORTANT: Horizontal vent sections require 1/4" (6mm) of rise for every 12" (305mm) of travel.

- (i) Minimum 12" Vertical Vent Pipe / Minimum Horizontal:  
12" (305mm) vertical vent pipe + 90° horizontal elbow + termination cap
- (i) Minimum 12" Vertical Vent Pipe / Maximum Horizontal:  
12" (305mm) vertical vent pipe + 90° horizontal elbow + 24" (610mm) maximum horizontal + termination cap
- (ii) Minimum 24" Vertical Vent Pipe / Minimum Horizontal:  
24" (610mm) vertical vent pipe + 90° horizontal elbow + termination cap
- (ii) Minimum 24" Vertical Vent Pipe / Maximum Horizontal:  
24" (610mm) vertical vent pipe + 90° horizontal elbow + 8' (2.44m) maximum horizontal + termination cap
- (iii) Minimum 36" Vertical Vent Pipe / Minimum Horizontal:  
36" (914mm) vertical vent pipe + 90° horizontal elbow + termination cap
- (iii) Minimum 36" Vertical Vent Pipe / Maximum Horizontal:  
36" (914mm) vertical vent pipe + 90° horizontal elbow + 12' (3.66m) maximum horizontal + termination cap
- (iv) Maximum 25' Vertical / Minimum Horizontal:  
25' (7.62m) maximum vertical vent length + 90° horizontal elbow + termination cap
- (iv) Maximum 25' Vertical / Maximum Horizontal:  
25' (7.62m) maximum vertical + 90° horizontal elbow + 25' (7.62m) maximum horizontal + termination cap

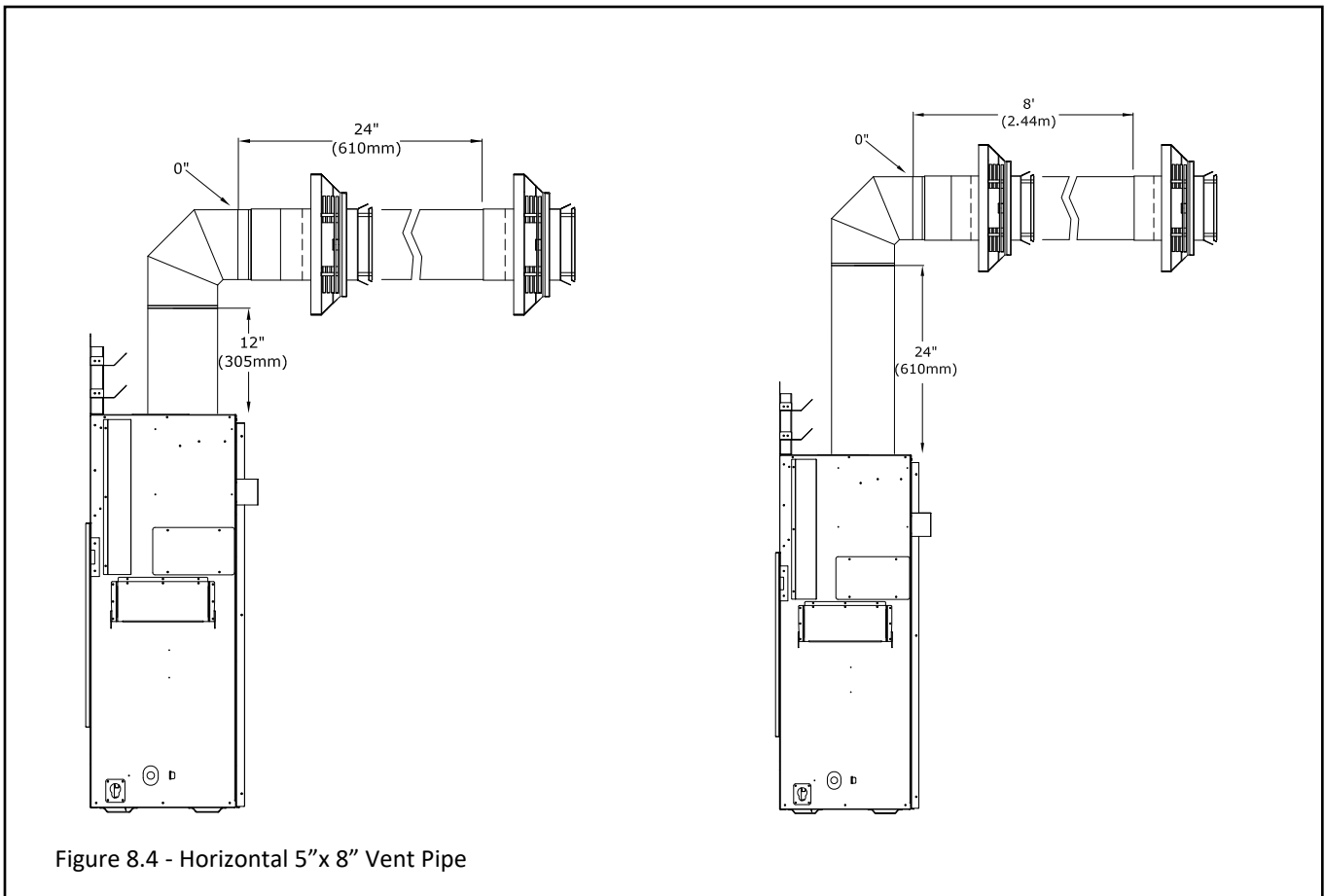

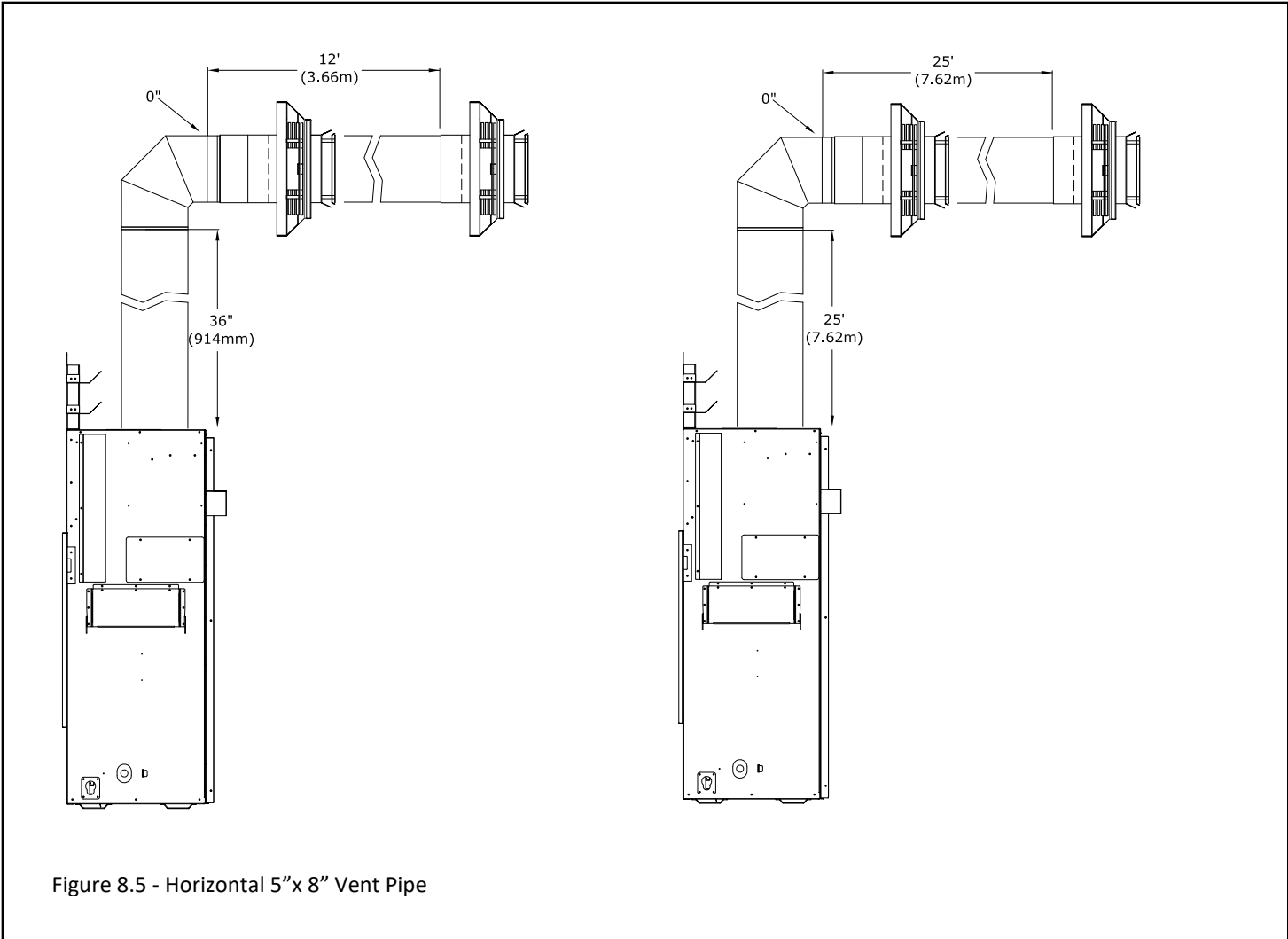

Figure 8.5 - Horizontal 5"x 8" Vent Pipe

### 8.5.3 Combination Venting

Note: Natural Gas and Propane Installations

Vent termination must be within the shaded area in FIGURE 8.6.

- 25' (7.62m) maximum vertical rise + 25' (7.62m) maximum horizontal run = 50' (15.2m) of total length
- Maximum of (5) 90° elbows. For each additional 90° elbow used after the first elbow, 3' (914mm) must be subtracted from maximum venting allowed.
- (2) 45° degree elbows may be used in place of (1) 90° elbow. For each 45° elbow used, 18" (457mm) must be subtracted from maximum venting allowed.

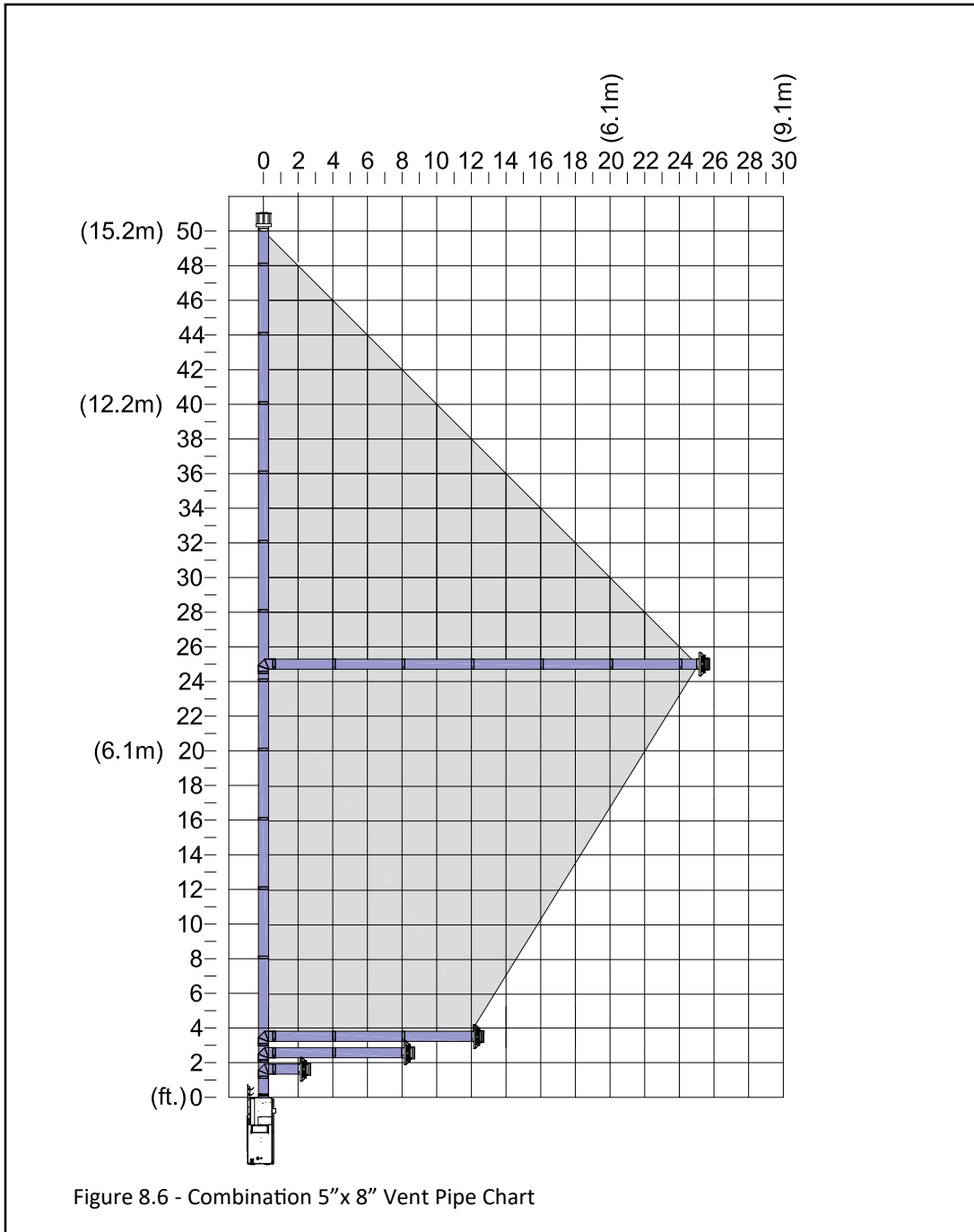

Figure 8.6 - Combination 5" x 8" Vent Pipe Chart

## 8.6 Class A Chimney / Masonry Chimney Conversion

This appliance is approved to be adapted for Class A/Masonry Chimney conversion with kits utilizing a 4" (102mm) flexible exhaust by any vent manufacturers listed in section 8.1, APPROVED VENT SYSTEMS.

Before conversion, have the existing installation inspected by a qualified chimney sweep or professional installer. The existing chimney system must be in serviceable condition, and functionally sound. Before proceeding with following installations, check with local building jurisdiction to verify this type of installation is allowed in your area.

Follow Figure 8.7 for allowable venting configurations for installation in existing through-the-ceiling, Class A/Masonry chimney. Route the exhaust gases and intake air through the existing Class A/Masonry chimney.

The gas appliance cannot be connected to a chimney flue that is serving a separate solid-fuel burning appliance.

### 8.6.1 4" Flex Pipe Venting Configurations

**IMPORTANT:** Horizontal vent sections require at least 1/4" (6mm) rise for every 12" (305mm) of travel.

**IMPORTANT:** The vent heat shield assembly must be installed when incorporating minimum horizontal venting off the top of the appliance.

**IMPORTANT:** Care should be taken when installing flexible pipe to avoid a tight bend that may cause abrasion or damage to the flexible pipe.

The vent option listed below allow for a minimum of 0" (0mm) to a maximum of 24" (610mm) horizontal run using rigid or flexible pipe.

#### (1) Minimum / Maximum Vertical Terminations

4" x 6-5/8" reducer + retro connector + 10' (3.05m) minimum length of 4" aluminum flexible pipe / 50' (15.24m) maximum length of 4" aluminum flexible pipe + top adapter + termination cap

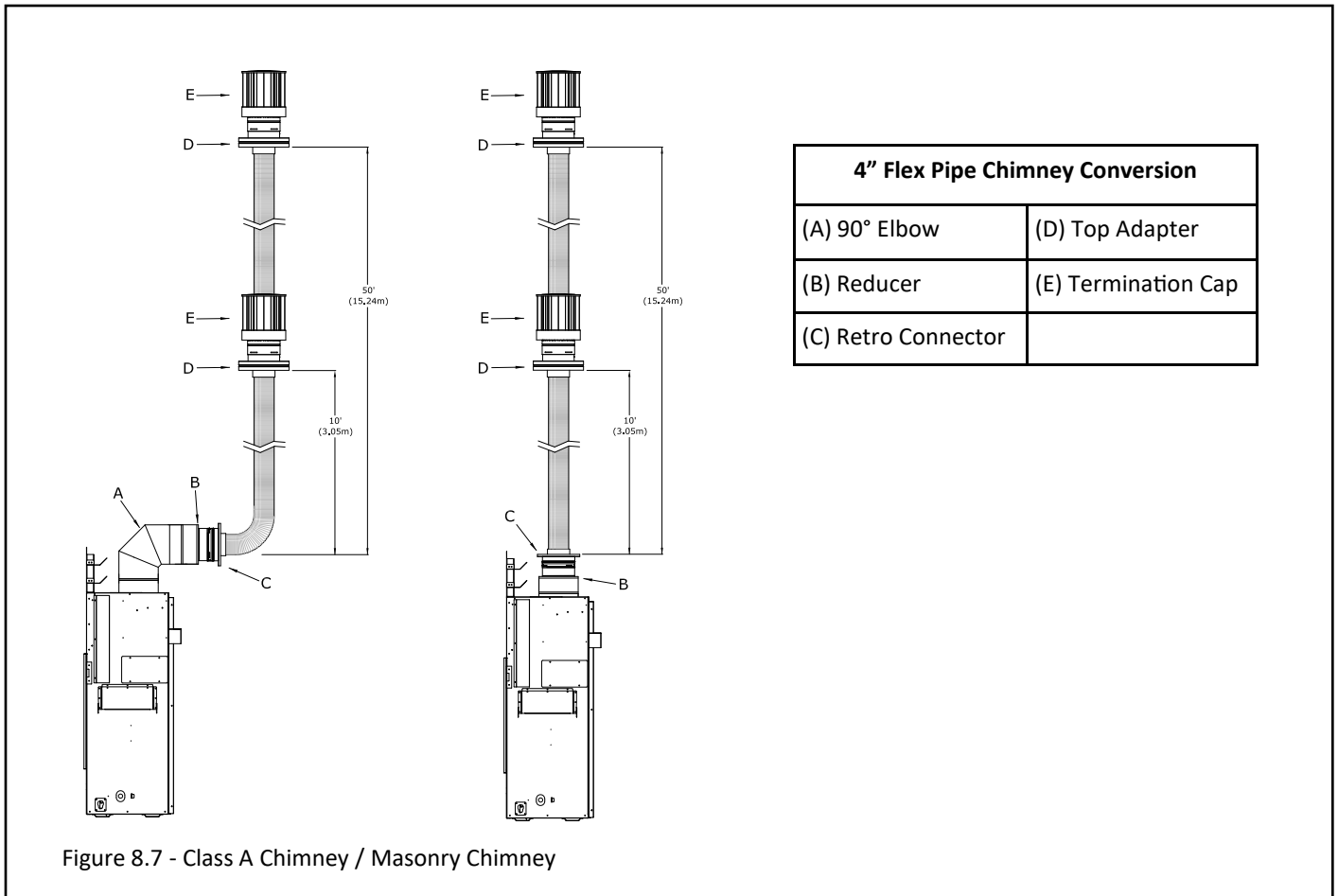

# 9.0 Fireplace Setup

## 9.1 Glass Frame Assembly

**WARNING:** Do not operate this fireplace with the glass removed, cracked, or broken. Replacement of the glass assembly, should be done by a licensed or qualified service person.

### 9.1.1 Remove Glass Frame Assembly

**WARNING:** Do not remove the glass assembly when hot.

1. Remove safety barrier.
2. Locate (4) spring-loaded latches securing the glass assembly at the top of the firebox.
3. Pull the spring-loaded latches out and up to release the top of the glass assembly.
4. Tilt the top glass assembly towards you and lift off of the support rail located at the bottom of the firebox.

### 9.1.2 Install Glass Frame Assembly

1. Tilt the top of the glass frame assembly as shown in Figure 9.1. Align the slot on bottom of the glass assembly on top of the rail at the bottom of the firebox while tilting the top of the glass assembly into position.
2. Pull the spring-loaded latches out and up to secure the top of glass to the top of the fireplace.
3. Reinstall safety barrier.

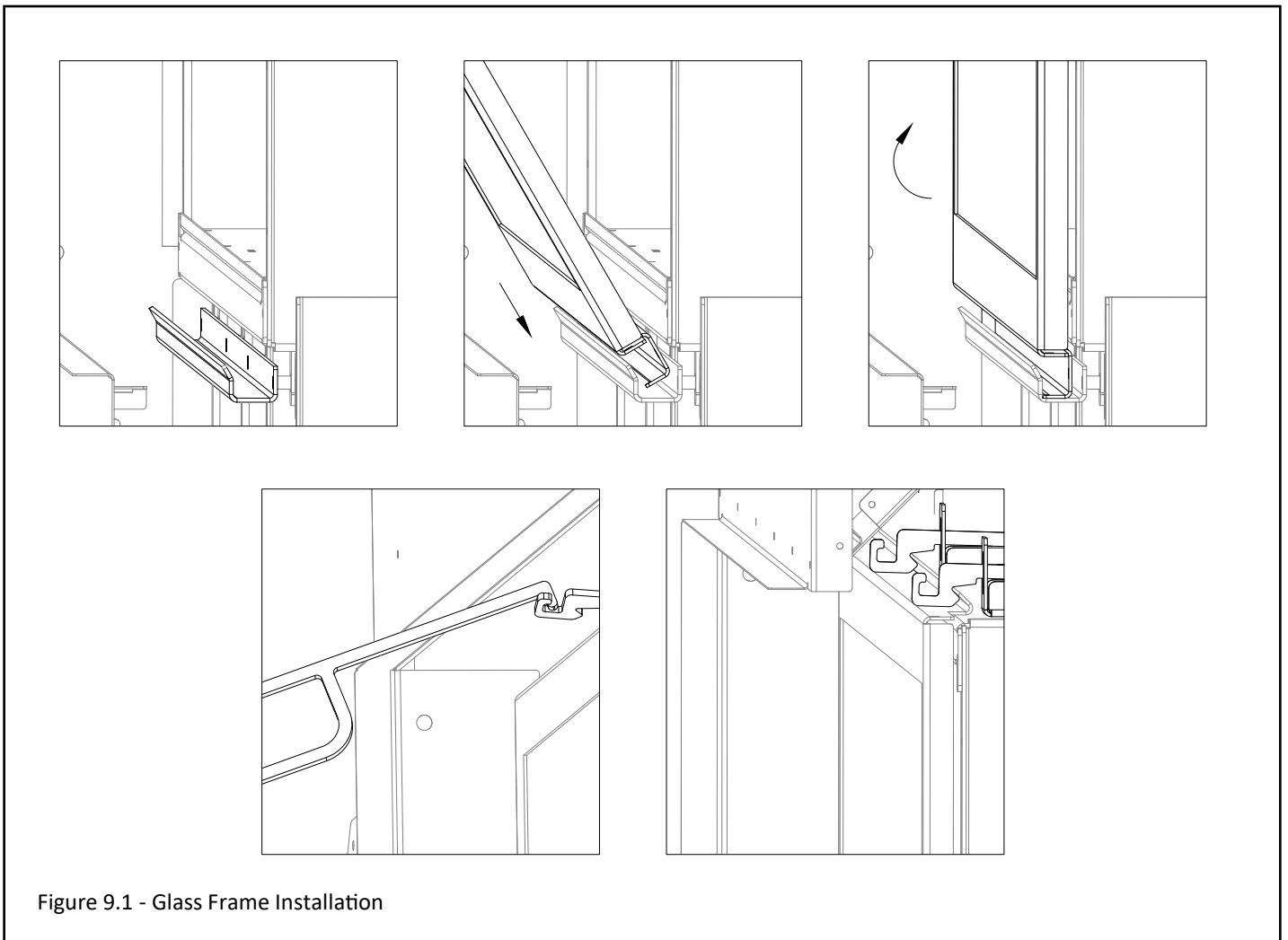
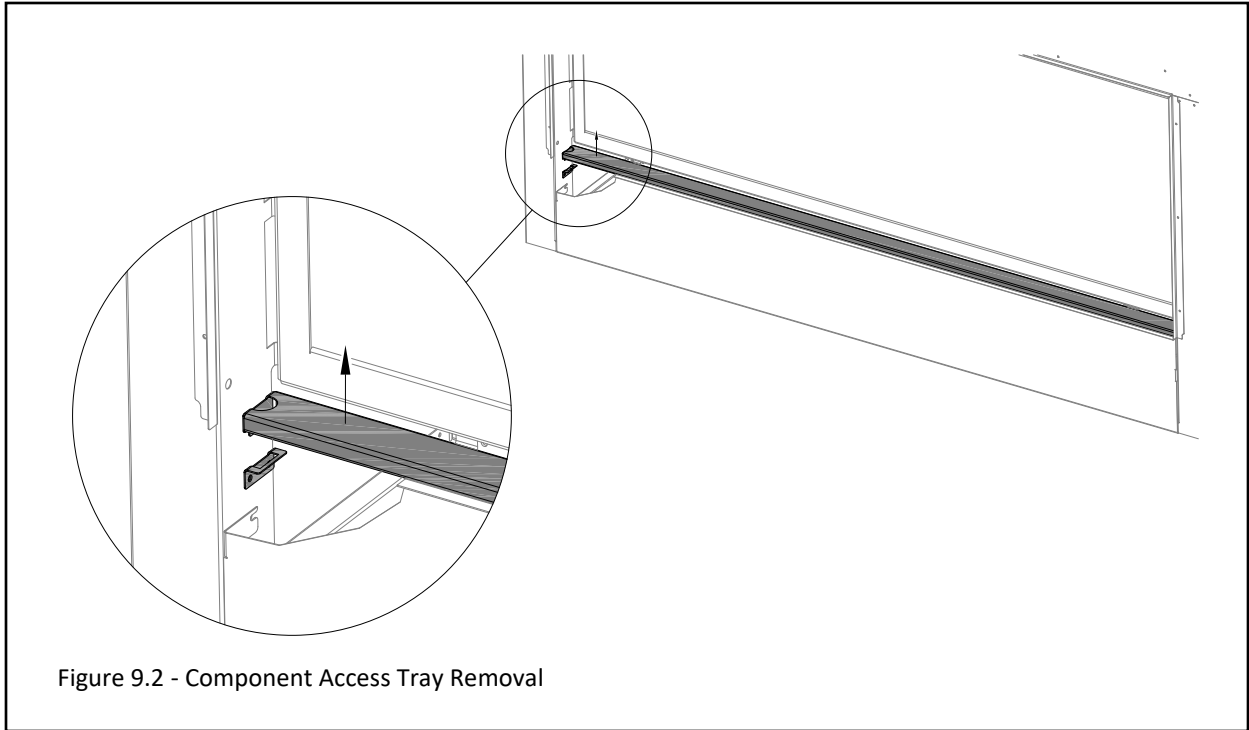

Figure 9.1 - Glass Frame Installation

## 9.2 Component Access Tray

To access the valve and control module housing, the component access tray will need to be removed. It must be reinstalled after servicing.

1. Remove safety barrier.
2. Lift up and remove the component access tray to gain access below the fireplace. See Figure 9.2.



## 9.3 Light Kits

**ATTENTION:** If converting to propane do so now before installing any light kit components. Follow instructions included with the conversion kit (sold separately).

**CAUTION:** Disconnect all electric power from fireplace before performing any of these tasks.

**NOTE:** To avoid damage and prolong the life of halogen bulbs, never touch with bare hands. Always use a soft cloth when handling.

### 9.3.1 Install Light Bulbs - Front Bottom Light Kit

**Note:** The front bottom light kit will not have the halogen bulb installed from the factory. Follow the instruction below for initial installation as well as bulb replacement.

1. Remove the safety barrier and glass frame assembly.
2. Remove log set, crushed glass media, and lava rock (if installed).
3. Remove and retain (2) screws from the front ember media tray. Lift tray up and out of firebox. See Figure 9.3.
4. Install (7) halogen bulbs (included in components packet) into the lamp bases.
5. Reinstall front ember bed media tray using screws previously removed.
6. Reinstall all components previously removed.

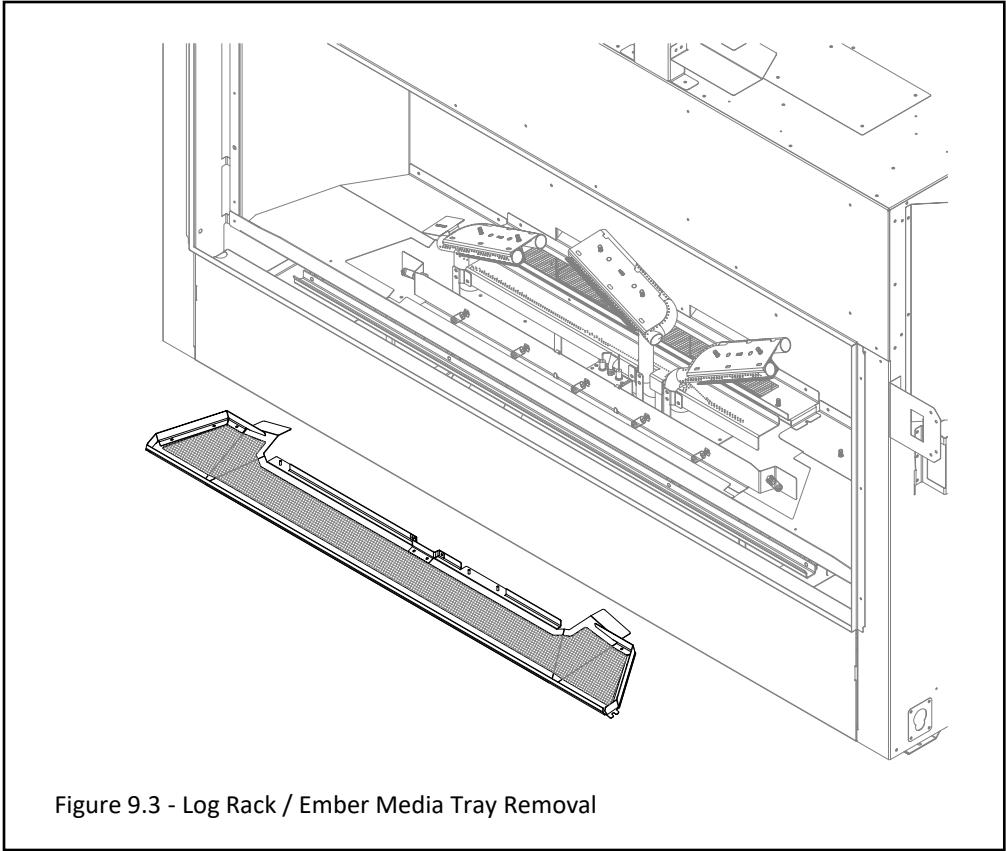

Figure 9.3 - Log Rack / Ember Media Tray Removal

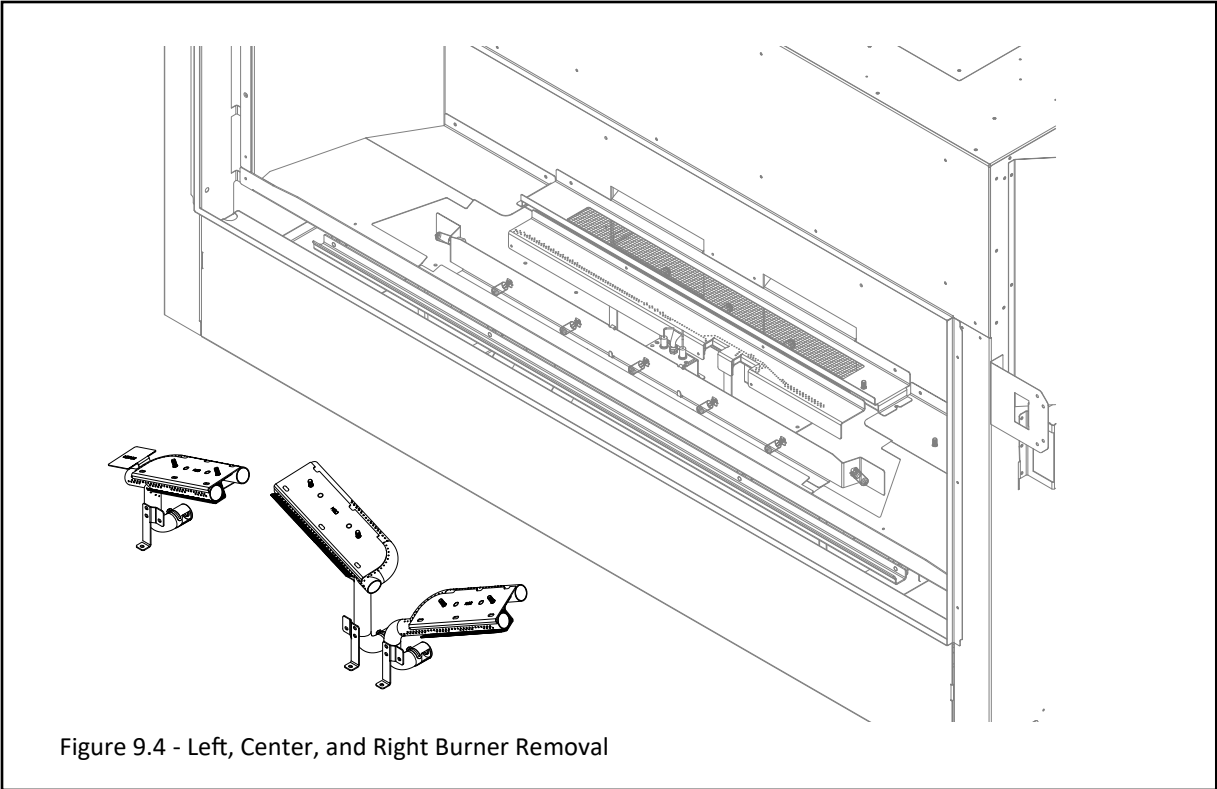

Figure 9.4 - Left, Center, and Right Burner Removal



### 9.3.2 Install Light Bulbs - Back Bottom Light Kit

- Halogen bulbs are preinstalled from the factory. See instructions below for bulb replacement.
  - Note: The instructions in Section 9.3.2 are a continuation of Section 9.3.1.
1. Remove and retain the (6) screws for the left, center, and right burners. Remove burners. See Figure 9.4.
  2. Remove and retain (2) screws from the back ember bed media tray. Remove media tray. See Figure 9.5.
  3. Install (3) halogen bulbs (included in components packet) into the lamp base.
  4. Reinstall all components previously removed.

### 9.3.3 Install Light Bulbs - Top Light Kit

Note: The top light kits will have the halogen bulbs installed from the factory. Follow the instruction below for bulb replacement.

1. Remove the safety barrier and glass frame assembly.
2. Remove the light kit cover, glass, and glass gasket via (4) screws.
3. Install (1) halogen bulb into the lamp base. There are (2) locations in the top of the firebox for halogen bulbs for the top light kit.
4. Reinstall all components previously removed. Ensure the glass gasketing is correctly installed.

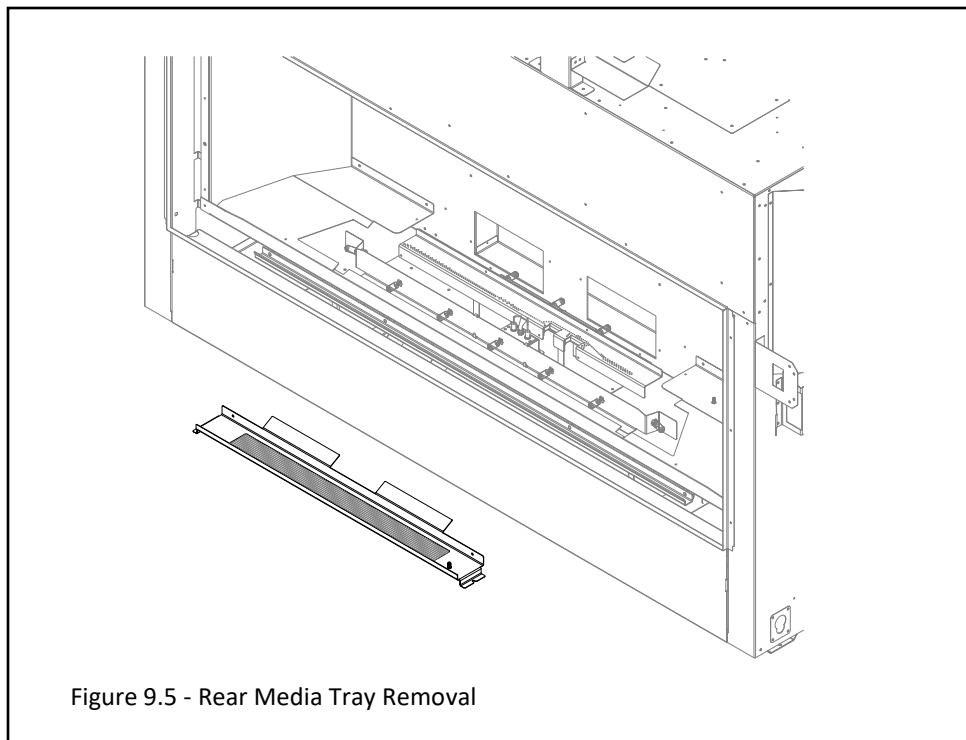

## 9.4 Log Set Installation

Refer to the instructions that are included with the log set you chose for this fireplace. There is a Traditional Log Set (Part #NK60TL-500) or Birch Log Set (Part #NK60TL-B501).

- *If converting to propane, complete the conversion before installing the log set. Follow the conversion instructions included with the kit.*
- *If installing a panel set, complete installation of panel set before log installation*

## 9.5 Control Board Removal and Installation

**WARNING:** If burner and/or pilot have been burning, use appropriate protection to avoid burns or damage to personal property before removing any components.

**DO NOT OPERATE THIS APPLIANCE WITHOUT THE SEALING GASKET (LOCATED UNDER THE CONTROL BOARD) IN PLACE. IF GASKETING IS DAMAGED, IT MUST BE REPLACED.**

**CAUTION:** Check all connections for leaks with soapy water, whether field or factory made.

### 9.5.1 Control Board Removal

1. Disconnect electrical power. Locate the main shut-off valve upstream of the appliance connector and close valve.
2. Remove the front media tray lift via (2) screws.
3. Remove front light kit via (2) screws. Remove left, center, and right burner assemblies. They are each held in by (2) screws. (1) screw secures it to the bottom burner and (1) screw secures it to the floor of the control board.
4. Remove the bottom burner assembly via (2) screws.
5. Remove the back media tray that covers the back ember bed light kit via (2) screws.
6. Remove the (12) screws securing the control board. Lift the control board out of the firebox, being careful not to damage the sealing gasket underneath.
7. Pull out control board out to reveal gas line to disconnect the gas line flex tube from fireplace valve.

### 9.5.2 Control Board Installation

1. Place control board in the firebox, aligning the holes in the control board with the holes in the firebox bottom. **VERIFY SEALING GASKET IS IN PLACE.**
2. Secure the control board to the firebox using (12) screws previously removed.
3. Reinstall the back ember bed media tray using the (2) screws previously removed.
4. Reinstall the rear burner assembly using the (2) screws previously removed.
5. Reinstall the left, center, and right burner assemblies using the (6) previously removed screws.
6. Reinstall front light kit with (2) screws previously removed.
7. Reinstall front ember bed media tray with the (2) screws previously removed.
8. Reconnect electrical power.
9. Verify proper log placement, operation of fireplace, and any electrical components.

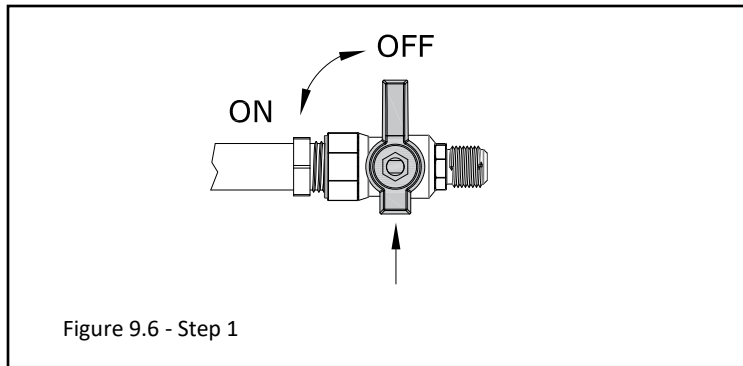

Figure 9.6 - Step 1

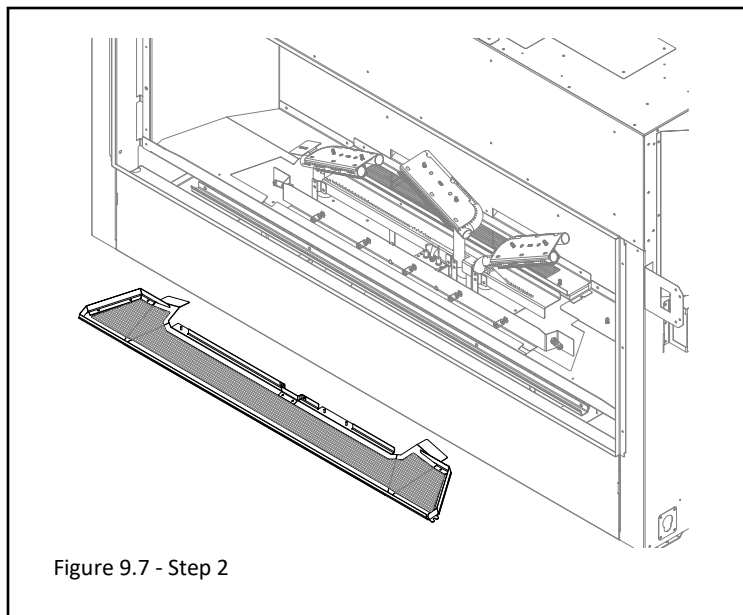

Figure 9.7 - Step 2

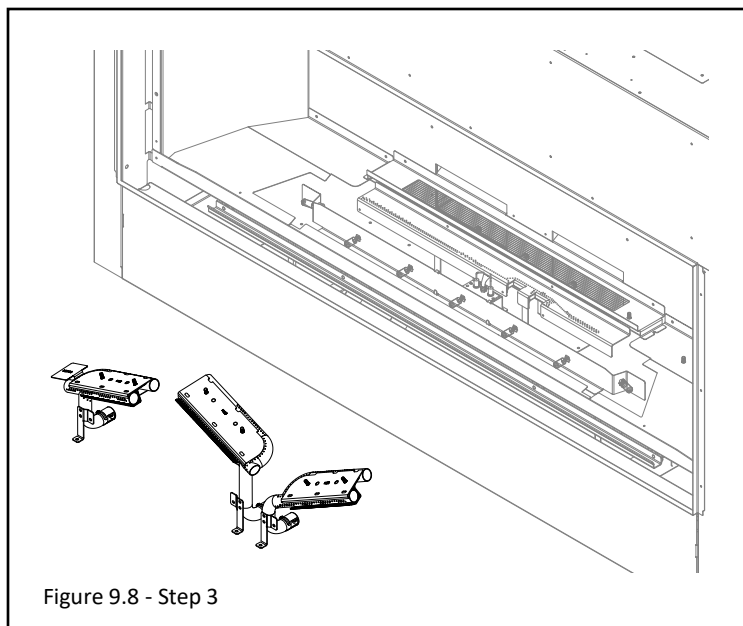

Figure 9.8 - Step 3

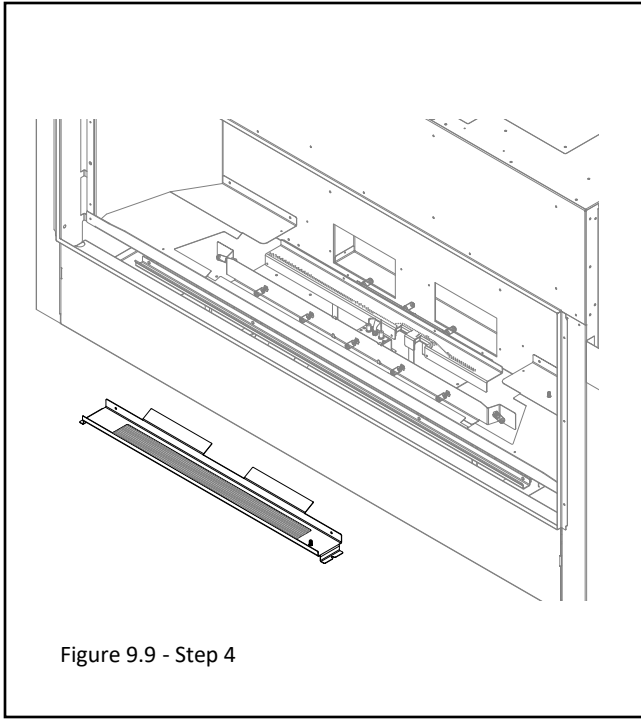

Figure 9.9 - Step 4

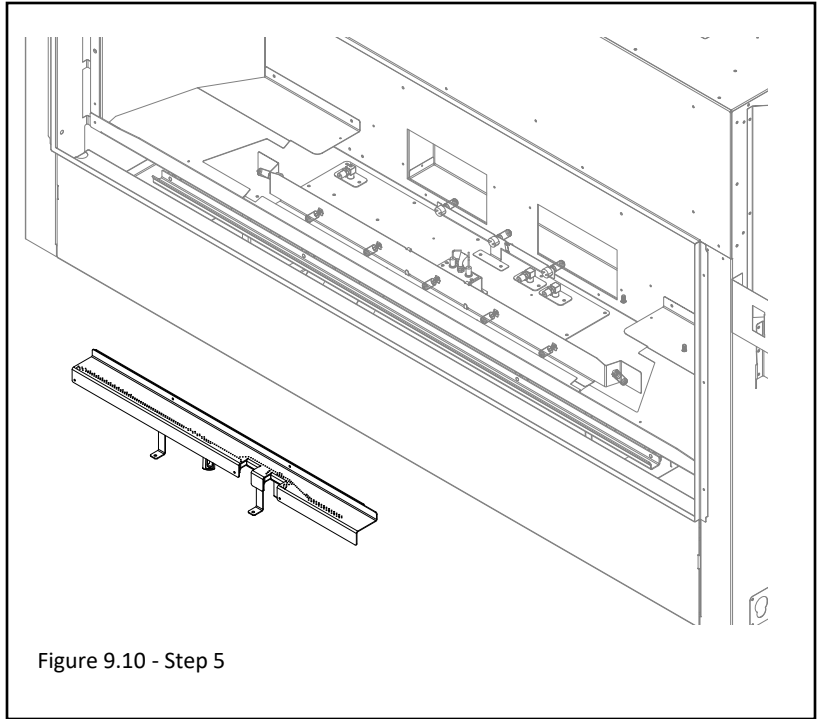

Figure 9.10 - Step 5

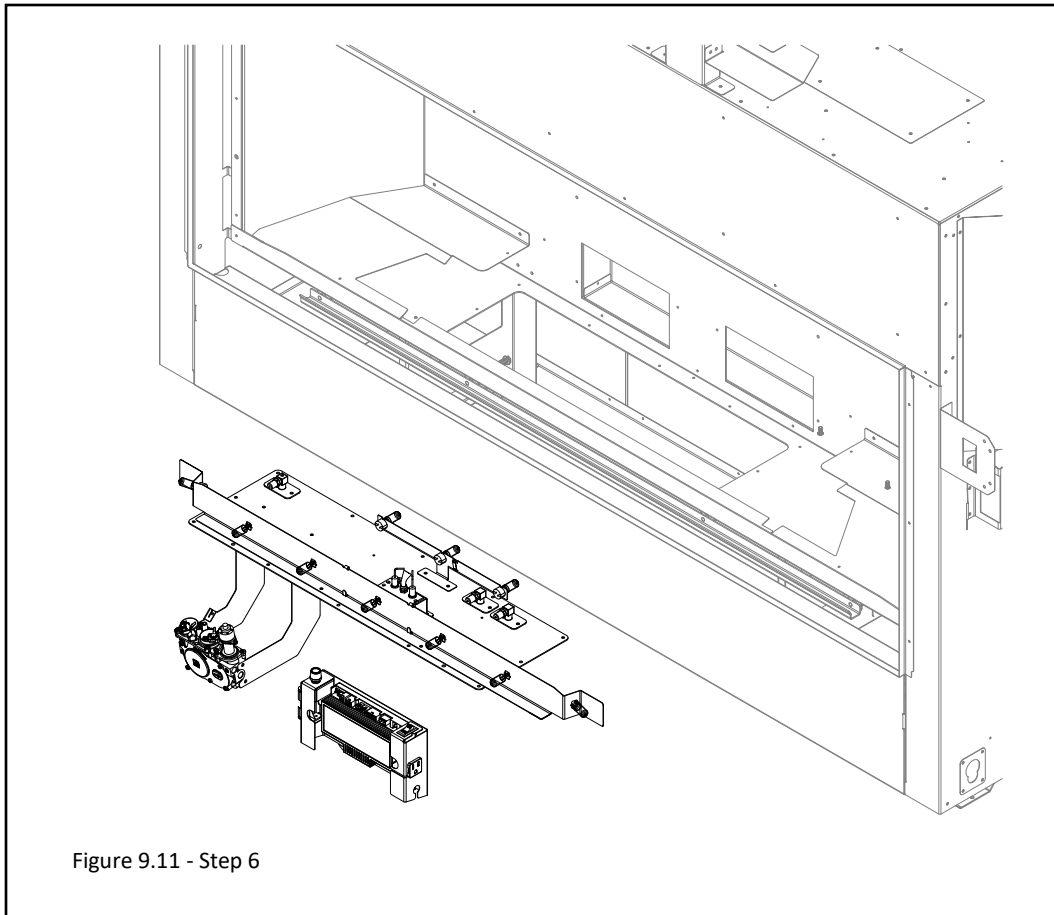

Figure 9.11 - Step 6

# 10.0 Electrical Information

**WARNING:** Do not use this fireplace if any part has been under water. Immediately call a qualified service technician to inspect this appliance and to replace any part of the control system and any gas control which has been under water.

**WARNING - Electrical Grounding Instructions:** This appliance is equipped with a three-prong (grounding) plug for your protection against shock hazard and should be plugged directly into a properly grounded three-prong receptacle. Do not cut or remove the grounding prong from this plug

## 10.1 Electrical Specifications

This appliance, when installed, must be electrically grounded in accordance with local codes, or in the absence of local codes, with the National Electrical Code, ANSI/NFPA 70, or the Canadian Electrical Code, CSA C22.1.

## 10.2 Wiring Requirements

- The system requires 120 VAC of electricity and/or batteries to operate.
- Using the battery backup will operate flame modulation of the burner.
- Fan and light components will not function on battery back up power

**Figure 10.1 - 10.3**

Note: Spade connectors are labeled “M” for male connectors and “F” for female connectors.

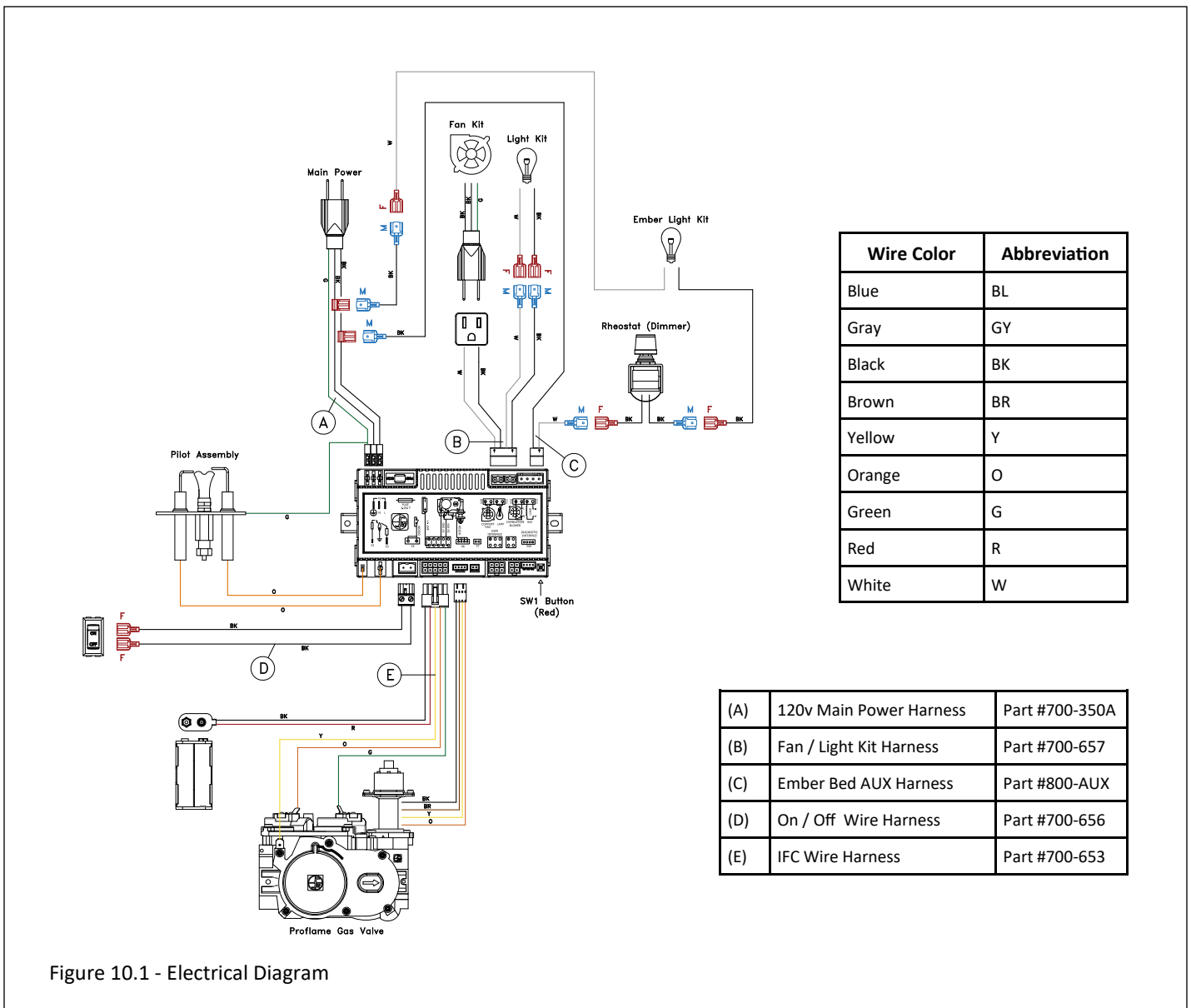
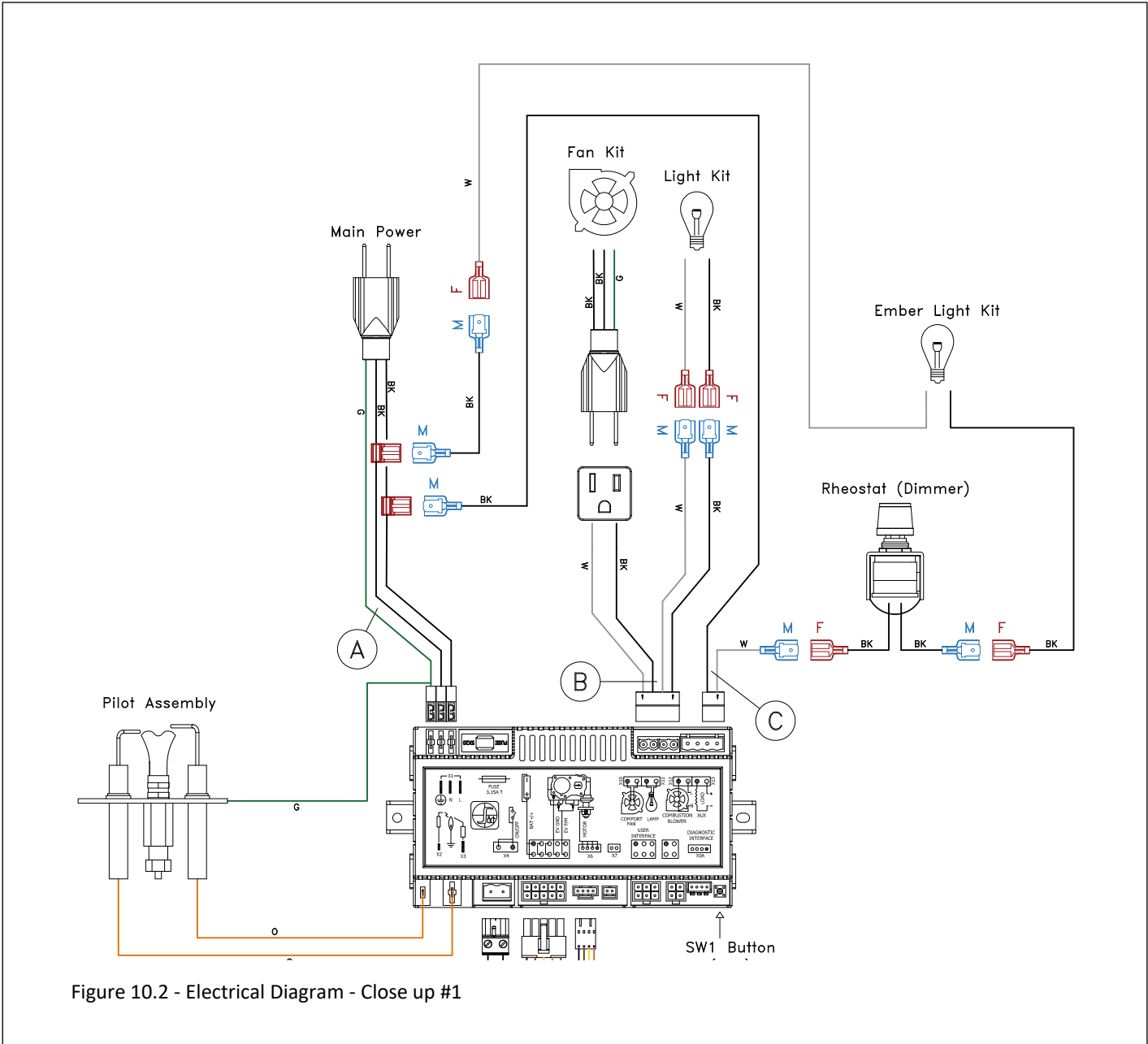

Figure 10.1 - Electrical Diagram

- Figure 10.2 shows a close up of the wiring diagram. This figure shows the main power cord, optional fan kit, top light kit, ember bed light kit, and pilot assembly.





# 11.0 Operating Instructions

## FOR YOUR SAFETY READ BEFORE OPERATING

**WARNING:** If you do not follow these instructions exactly, a fire or explosion may result causing property damage, personal injury, or loss of life.

- A. This appliance is equipped with an ignition device which automatically lights the pilot. Do not try to light the pilot by hand.
- B. **BEFORE OPERATING** smell around the appliance area for gas. Be sure to smell next to the floor because some gas is heavier than air and will settle on the floor.  
**WHAT TO DO IF YOU SMELL GAS**
  - Do not try to light any appliance.
  - Do not touch any electric switch; do not use any phone in your building.
  - Immediately call your gas supplier from a neighbor's phone.
- C. Follow the gas supplier's instructions.
  - If you cannot reach your gas supplier, call the fire department.
- D. Use only your hand to turn the gas control manual valve. Never use tools. If the valve will not turn by hand, do not try to repair it; call a qualified service technician. Force or attempted repair may result in a fire or explosion.
- E. Do not use this appliance if any part has been under water. Immediately call a qualified service technician to inspect the appliance and to replace any part of the control system and any gas control that has been under water.

### WARNING

Do not operate appliance with the glass front removed, cracked, or broken. Replacement of the glass should be done by a licensed or qualified service person.

Under no circumstances should any solid fuel (wood, coal, paper, cardboard, etc.) be used in this appliance.



Children and adults should be alerted to the hazards of high surface temperature and should stay away to avoid burns or clothing ignition.

### CAUTION

Clothing or other flammable material should not be placed on or near the appliance.

Young children should be carefully supervised when they are in the same room as the appliance. Toddlers, young children and others may be susceptible to accidental contact burns. A physical barrier is recommended if there are at risk individuals in the house. To restrict access to a fireplace or stove, install an adjustable safety gate to keep toddlers, young children and other at risk individuals out of the room and away from hot surfaces.

## OPERATING INSTRUCTIONS

1. STOP! Read all the safety information above on this page.
2. Press the wireless remote OFF button.
3. Turn off all electric power to the appliance.
4. This appliance is equipped with an ignition device which automatically lights the pilot. Do not try to light the pilot by hand.
5. Locate the manual valve installed by your qualified service technician.
6. Turn the manual valve clockwise  to the OFF position.
7. Wait five (5) minutes to clear  out any gas. Then, smell for gas, including near the floor. If you smell gas, STOP! Follow 'B' in the safety information above. If you do not smell gas, go to the next step.
8. Turn the manual valve counterclockwise  to the ON position.
9. Turn on all electric power to the appliance.
10. Press the wireless remote ON button.
11. If the appliance will not operate, follow the instructions, "To Turn Off Gas To Appliance" and call your service technician or gas supplier.

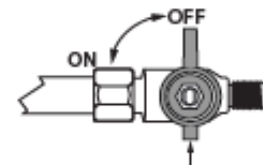

## TO TURN OFF GAS TO APPLIANCE

1. Press the wireless remote OFF button.
2. Turn off all electric power to the appliance if service is to be performed.
3. Locate the manual valve installed by your qualified service technician.
4. Turn the manual valve clockwise  to OFF position.

### NOTE

When this fireplace is initially lit, condensation will appear on the glass. This is normal in all gas fireplaces and will disappear after several minutes. A paint smell will occur during the first few hours of burning. It is recommended to leave the fan off during this period to help speed the paint curing process.

This fireplace may produce noises of varying degree as it heats and cools due to metal expansion and contraction. This is normal, and does not affect the performance or longevity of the fireplace.

### 11.1 Setup Proflame 2 IFC Module

1. Set the main ON/OFF rocker switch in the OFF position.
2. Install (4) AA batteries (not included) into backup battery holder on the control module.
3. Install (3) AAA batteries (included in the components packet) in the remote control battery bay, located at the base of the remote.
4. Connect the IFC Module to an AC power supply.

### 11.2 Initialize the Control System

**IMPORTANT: Remove all packaging and combustible material from the firebox before initializing the control system.**

**NOTE: Performing the next steps will initiate pilot start-up in manual mode, where the pilot igniter will spark repeatedly. The pilot will ignite if gas is supplied to the fireplace.**

1. To access the ON/OFF toggle switch and remote learn button on, remove the safety barrier screen by lifting up and out of its slots.
2. Remove the component access tray (See Section 9.2). Locate the remote sync button by sliding out the control module.
3. Press the remote sync button. The IFC module will BEEP (3) times and illuminate an amber LED. This indicates the receiver is ready to synchronize with the transmitter.
4. Within (5) seconds, push the ON/OFF button on the remote control. The receiver will BEEP (4) times to indicate the transmitter's command is accepted, and is set to the transmitter's particular code. The pilot will automatically ignite.
5. Press the remote control ON/OFF button again. The pilot will extinguish, confirming the remote control command. The control system is now initialized.
6. Set the main ON/OFF rocker switch to ON position for remote control operation of the main burner and fireplace features. Reinstall safety barrier screen.

### 11.3 Reset the System for Manual Operation

1. Access the toggle switch and remote learn button on the left side of the unit by removing the safety barrier screen by lifting up and out of its slots.
  2. Remove the component access tray (See Section 9.2). Locate the remote sync button by sliding out the control module.
  3. Set the ON/OFF rocker switch to OFF position.
  4. Press and hold the remote sync button until it emits (3) beeps and an amber LED is illuminated.
  5. Within (5) seconds, press the remote sync button again. This will close synchronization with the remote control. The pilot will automatically light.
- Turn the main burner ON by setting the ON/OFF switch in ON position. The main burner will only operate on HI.
  - Turn the main burner OFF by setting the ON/OFF switch in the OFF position. The pilot will remain lit even if burner is turned off, provided CPI mode is turned on.

### 11.4 Automatic Safety Turn-off

- This system will execute an automatic turn OFF command for approximately (5) seconds within (24) hours of a continued pilot flame ignition to perform a safety check. This allows the system to verify correct safety functions.
- After the turn OFF sequence is completed, the IFC module will re-execute the latest command.

### 11.5 Backup Battery Operation

This appliance will operate on the backup battery pack when electric power is interrupted, or in a power outage. During the power outage, the appliance burner and flame height adjustment will function. The fan and accent light kit will not function.

- The lifespan of the backup batteries depend on various factors, such as the quality of the batteries, number of ignitions, etc.
- When the backup battery pack is low, the IFC module will emit a double-beep while receiving an ON/OFF command. No commands will be accepted after this alert until the back up batteries are replaced. Once replaced, the IFC module will emit a 'beep' as soon as it is powered.



## 11.6 Control System 7 Day Timeout

- If you have your Proflame 2 system set to CPI (continuous pilot ignition) with 7 consecutive days without ignition of the main burner, the pilot will turn off. This is a standard safety feature of the SIT Proflame 2 system.
- Once you turn CPI on, the 7 day timer will start. If at any time during the following 7 days your main burner ignites, it will reset the timer back to 7 days.
- See section 11.9.3 PILOT IGNITION SELECTION for more information.

### How to check if your system is set to CPI:

The LCD screen will display the snowflake icon.

### To select the preferred pilot ignition feature,

1. With the system in the OFF position, press the mode key to index the CPI mode icon.
2. Press the up arrow key to activate CPI.
3. Press the down arrow key to return to IPI. A single 'beep' will confirm reception of the command.

### To Turn ON the appliance

1. With the system in the OFF position, press the remote control ON/OFF key to turn ON the appliance. A single 'beep' will emit from the IFC module to confirm reception of the command.

The LCD screen will display all active icons, and the IFC module will start the ignition sequence.

## 11.7 IFC Module Ignition Sequence

The IFC module will try (2) times for ignition, each lasting approximately (60) seconds, with approximately (35) seconds between each attempt.

1. With the system in OFF position, press the remote control ON/OFF key. Approximately (4) seconds after this key is depressed, the IFC module will generate sparks to the pilot hood.
2. First ignition attempt will generate sparks for (60) seconds.
3. If there is no flame ignition (rectification) within the (60) second time frame, the IFC module will stop generating sparks for approximately (35) seconds.
4. After (35) seconds of wait time, the IFC module will generate sparks for another (60) seconds for the second ignition attempt.
5. If there is no positive rectification after (60) seconds, the IFC module will go into a lock out. The red LED will blink (3) times, in intervals, until the system is reset.

### 11.7.1 Reset IFC Module after Lockout

#### 11.7.1.1 ON/OFF Rocker Switch

1. Set the ON/OFF rocker switch to the OFF position.
2. After approximately (2) seconds, move the switch to the ON position. The ignition sequence will start again.

### 11.7.1.2 Remote Control ON/OFF Key

1. Press the remote control ON/OFF key to turn the system OFF.
2. After approximately (2) seconds, press the ON/OFF key again. The ignition sequence will start again.

### 11.7.1.3 Cycling Flame

1. Press the remote control down arrow key during flame adjustment mode to reduce the flame to OFF (indicated by OFF displayed on the LCD screen).
2. After approximately (2) seconds, press the up arrow key. The ignition sequence will start again.

## 11.8 Additional Diagnostic Information

### Low Battery Condition (<4V) Remote Control:

- Battery Icon will appear on LCD remote control display.
- Replace batteries.

### Low Battery Condition (<4V) Battery Backup:

- The red LED Indicator will blink (1) time in intervals.
- A low double-beep emits from the IFC control module when it receives an ON/OFF command from the remote control.
- Replace Batteries.

### Pilot Flame Error Condition:

- Red LED Indicator will blink (2) times in intervals. Contact your dealer if this occurs.

### System Lock Out Condition:

- Red LED Indicator will blink (3) times in intervals.
- Verify gas is turned on.
- Verify sensor is not shorted.
- Follow section 11.2, INITIALIZE THE CONTROL SYSTEM .

## 11.9 Remote Control Operation

### PROFLAME 2 TRANSMITTER

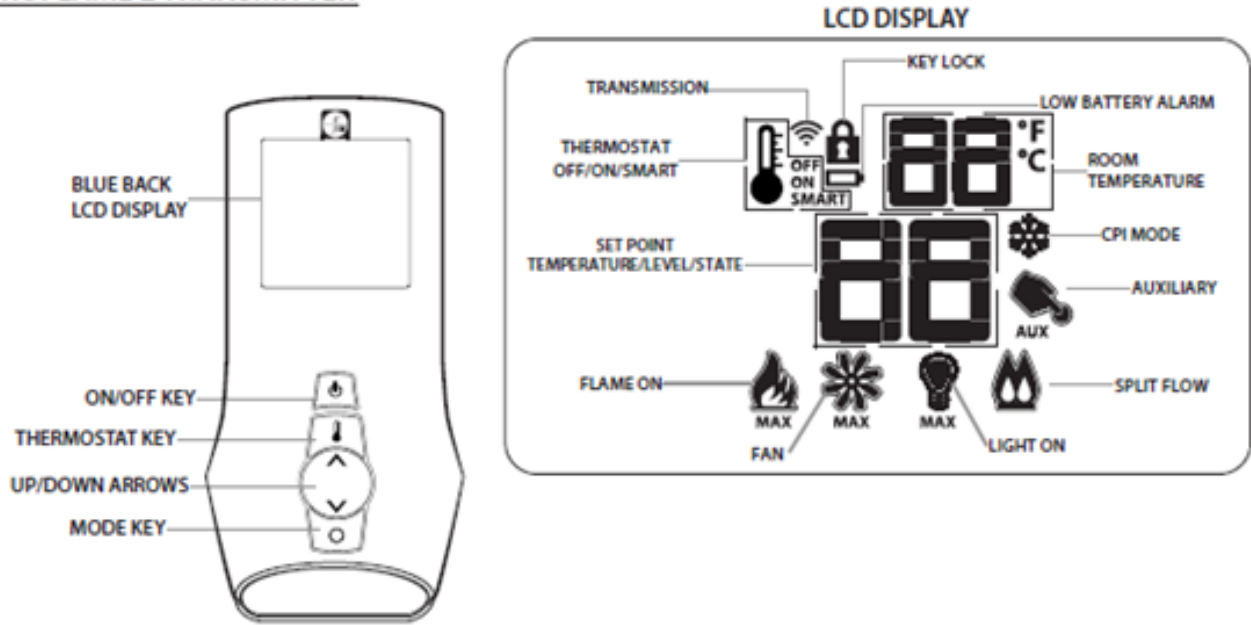

Figure 11.1 - Remote control overview

#### 11.9.1 Temperature Display

1. With the system in the OFF position, simultaneously press the thermostat key and the mode key to change degrees from °F to °C
2. Visually check the LCD screen to verify either °F or °C is displayed on the right side of the room temperature display.

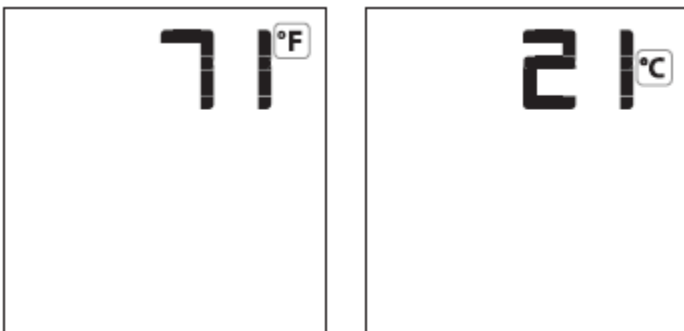

Figure 11.2 - Temperature Display

#### 11.9.2 Key Lock

This function locks the keys to avoid unsupervised operation. Once activated, a lock icon will appear on the LCD screen.

1. Simultaneously press the mode key and the up arrow key to activate or deactivate this function.



Figure 11.3 - Key Lock

### 11.9.3 Pilot Ignition Selection (IPI/CPI)

This system has the option of a continuous (standing) pilot. This features allows the system to change from a spark-to-pilot system to the standing pilot option. The standing pilot will keep the firebox warm and establish a draft in the vent, which allows the main burner to ignite with less air-flow disruption.

When the system is OFF, the LCD screen will display the snowflake icon during the setup of either IPI or CPI mode. To select the preferred pilot ignition feature,

1. With the system in the OFF position, press the mode key to index the CPI mode icon.
2. Press the up arrow key to activate CPI.
3. Press the down arrow key to return to IPI. A single 'beep' will confirm reception of the command.

When the system is ON,

IPI mode: LCD screen will not display the snowflake icon

CPI mode: LCD screen will display the snowflake icon

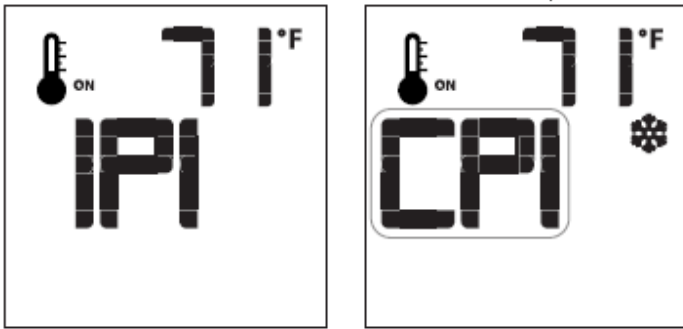

Figure 11.4 - Pilot Selection

### 11.9.4 Turn ON the Appliance

1. With the system in the OFF position, press the remote control ON/OFF key to turn ON the appliance. A single 'beep' will emit from the IFC module to confirm reception of the command.

The LCD screen will display all active icons, and the IFC module will start the ignition sequence.

### 11.9.5 Turn OFF the appliance

1. With the system in the OFF position, press the remote control ON/OFF key to turn ON the appliance. A single 'beep' will emit from the IFC module to confirm reception of the command.

The LCD screen will only display the room temperature and its icon, and the IFC module will turn off the main burner.

### 11.9.6 Remote Control Flame Adjustment

This control system has (6) flame levels. If the smart thermostat operation is activated, then the manual adjustment of the flame height will be disabled.

1. Verify the system is in the ON position and the flame level is set at maximum.
2. Press the down arrow key once to reduce flame height by one level until the flame is turned off.
3. Press the up arrow key once to increase flame height by one step. If the up arrow key is pressed while the system is on, but the flame is off, the flame will ignite on HI.
4. A single 'beep' will confirm reception of the command.

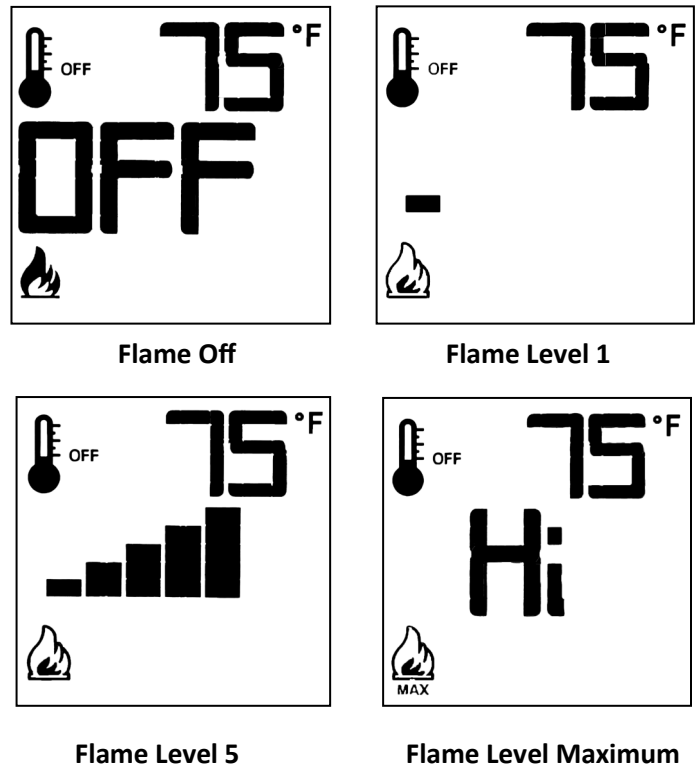

Figure 11.5 - Flame Adjustment

### 11.9.6.1 Deactivate Flame Modulation

1. Verify all (3) AAA batteries are installed in the remote control battery bay.
2. Remove (1) AAA battery.
3. Press and hold the on/off key and the mode key at the same time.
4. Reinsert (1) AAA battery.
5. While still holding the on/off key, let go of ONLY the mode key.
6. Index over to the flame graphic on the LCD screen to edit. Use the up or down arrow key to choose 'SEL' or 'CLR'. "SEL" means flame modulation is turned on and "CLR" means flame modulation is turned off.

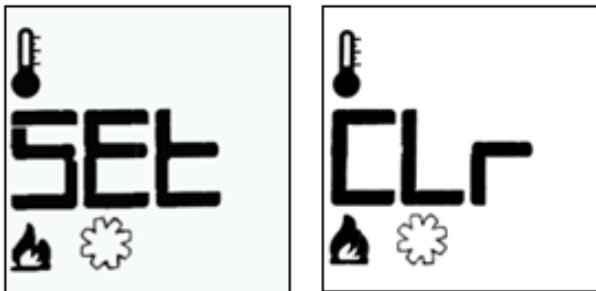

Figure 11.6 - Deactivate Flame Modulation

### 11.9.7 Remote Control Thermostat Operation

#### 11.9.7.1 Room Thermostat

The remote control can operate as a room thermostat. The thermostat can be set to a desired temperature to control a room's comfort level. To activate this function,

1. Press the thermostat key. The LCD screen will display a temperature bulb graphic, the room temperature and set temperature.
2. To adjust the set temperature, press the up or down arrow keys until the desired temperature is displayed on the LCD screen.

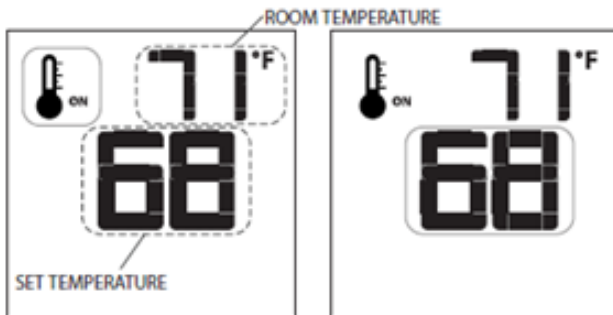

Figure 11.7 - Thermostat Operation

### 11.9.7.2 Smart Thermostat

The smart thermostat function will adjust the flame height based on the set temperature and the actual room temperature. The smart thermostat function automatically adjusts the flame down when the room temperature reaches the set point. To activate this function,

1. Press the thermostat key until the 'SMART' appears on LCD screen on the right side of the temperature bulb graphic.
2. To adjust the set temperature, press the up or down arrow keys until the desired temperature is displayed on the LCD screen.

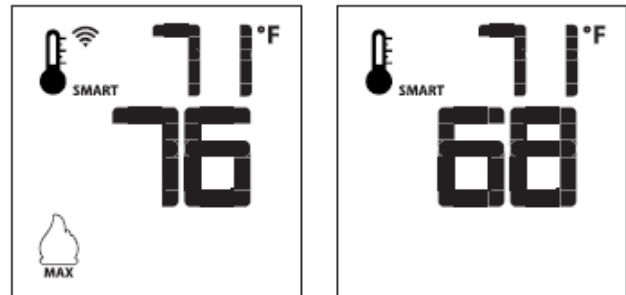

Figure 11.8 - Smart Thermostat Operation

#### 11.9.7.3 Deactivate Remote Control Thermostat Operation

The thermostat operation function can be deactivated. The remote control will still operate the main burner on and off, and function flame, fan, and light modulation. To deactivate this function,

1. Verify all (3) AAA batteries are installed in the remote control.
  2. Remove (1) AAA battery.
  3. While reinserting the battery, push and hold the thermostat key. You will see "CLR" across the screen. This means the thermostat function is turned off. The temperature bulb graphic will not be displayed on the LCD screen.
- To reactivate remote thermostat operation, follow the same key sequence procedure above. The screen will then say "SEL" which means the thermostat function is turned on. The temperature bulb graphic will reappear on the LCD screen.

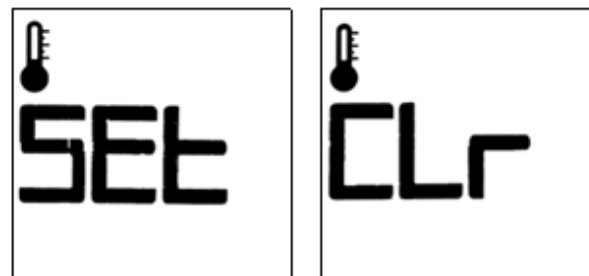

Figure 11.9 - Deactivate Thermostat Operation

### 11.9.8 Fan Speed Control

Fan speed can be adjusted through (6) speeds. To activate this function,

1. Press the mode key to index to the fan control icon.
2. Press the up or down arrow keys to turn on, off, or to adjust fan speed.

Thermostat mode: Fan(s) have a (5) minute delay time when the fireplace is lit. This allows time for heat to build in fireplace before fan operation. The fan will continue to operate for approximately (12) minutes after the fireplace has been turned off.

Manual mode: Fan(s) will operate at previous setting. There is no delay in start up or stop time.

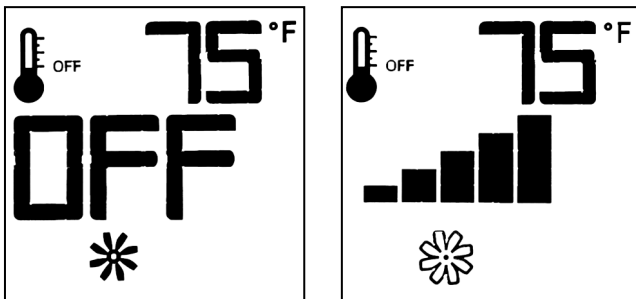

Figure 11.10 - Fan adjustment

#### 11.9.8.1 Deactivation Fan Speed Control

Fan speed can be adjusted through (6) speeds. To activate this function,

1. Verify all (3) AAA batteries are installed in the remote control battery bay.
2. Remove (1) AAA battery.
3. Press and hold the on/off key and the mode key at the same time.
4. Reinsert (1) AAA battery.
5. While still holding the on/off key, let go of ONLY the mode key.
6. Index over to the fan control icon on the LCD screen to edit. Use the up or down arrow key to choose 'SEL' or 'CLR'.

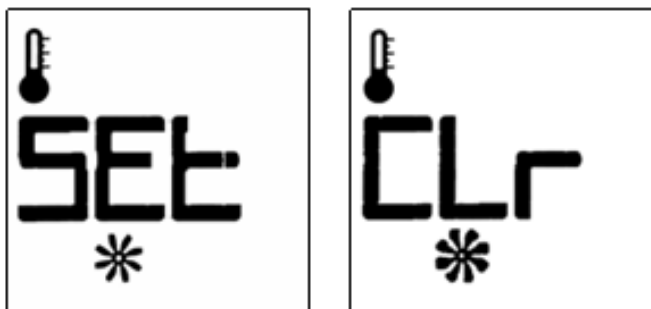

Figure 11.11 - Fan Control Deactivation

### 11.9.9 Top Accent Light Kit

The top light intensity can be adjusted through (6) levels.

1. Press the mode key to index to the light icon.
2. Press the up or down arrow keys to adjust the intensity level.
3. A single 'beep' will confirm reception of the command.

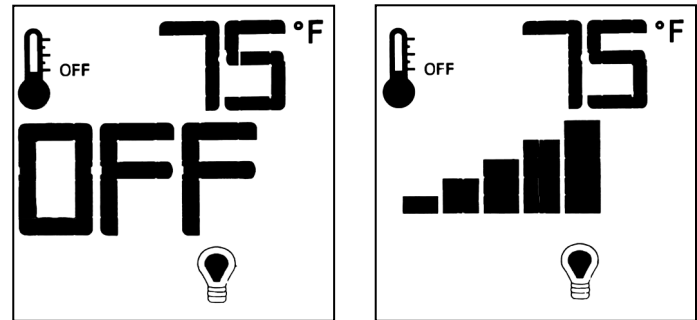

Figure 11.12 - Top Light Kit

#### 11.9.9.1 Deactivation Light Kit Modulation

1. Verify all (3) AAA batteries are installed in the remote control battery bay.
2. Remove (1) AAA battery.
3. Press and hold the on/off key and the mode key at the same time.
4. Reinsert (1) AAA battery.
5. While still holding the on/off key, let go of ONLY the mode key.
6. Index over to the bulb graphic on the LCD screen to edit. Use the up or down arrow key to choose 'SEL' or 'CLR'.



Figure 11.13 - Light Kit Deactivation

### 11.9.10 Activate Ember Bed Light Kit (auxiliary)

The auxiliary function controls ON/OFF function the ember bed light kit. To activate this function,

1. Verify all (3) AAA batteries are installed in the remote control battery bay.
2. Remove (1) AAA battery.
3. Press and hold the on/off key and the mode key at the same time.
4. Reinsert (1) AAA battery.
5. While still holding the on/off key, let go of ONLY the mode key.
6. Index over to the hand graphic on the LCD screen to edit. Use the up or down arrow key to choose 'SEL' or 'CLR'.

To turn on the Ember Bed Light Kit

1. Press the mode key to index to the AUX icon.
2. Press the up arrow key to turn the ember bed light kit ON.
3. Press the down arrow key to turn the ember bed light kit OFF.
4. A single 'beep' will confirm reception of the command.

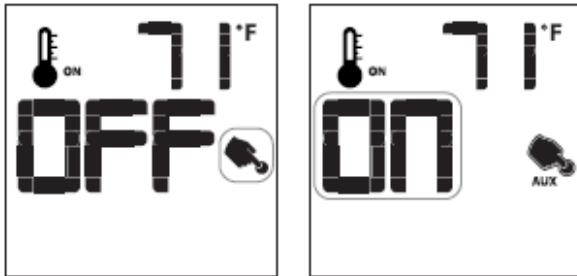

Figure 11.14 - Ember Bed Light Kit

### 11.9.10.1 Adjust Ember Bed Light Kit Intensity (after turning "ON")

The ember bed light kit intensity can be adjusted by using the ember bed light kit modulator knob located underneath the firebox (FIGURE 11.15). To adjust,

1. Remove the safety barrier screen by lifting the screen up and out of the slots.
2. Turn the knob counterclockwise to decrease the light intensity.
3. Turn the knob clockwise to increase the light intensity.
4. Reinstall safety barrier screen when finished.

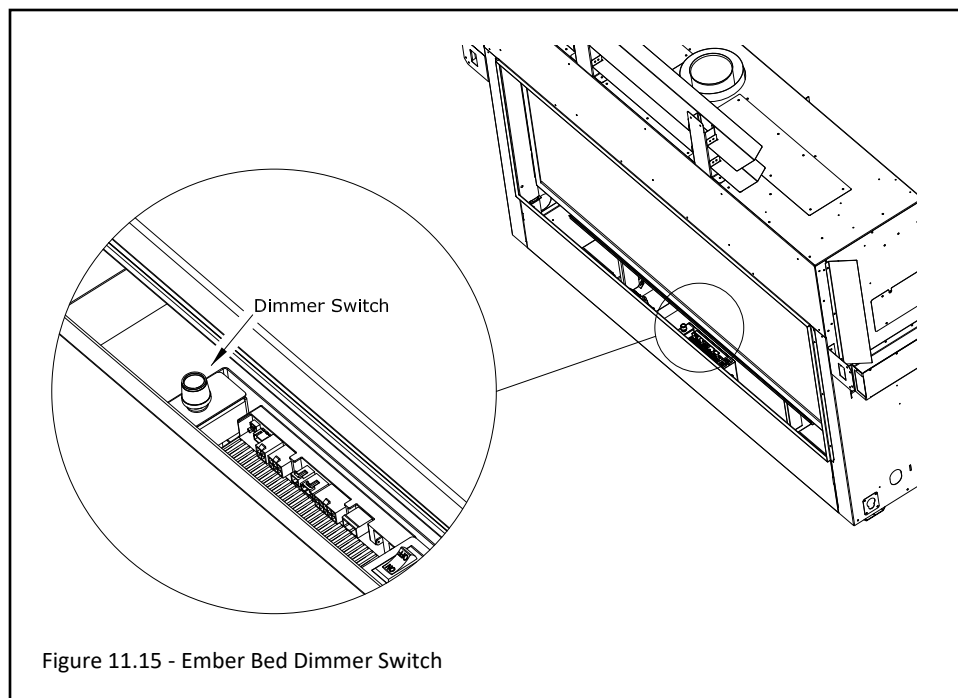

Figure 11.15 - Ember Bed Dimmer Switch

### 11.9.10.2 Deactivation AUX (Ember Bed Light Kit)

1. Verify all (3) AAA batteries are installed in the remote control battery bay.
2. Remove (1) AAA battery.
3. Press and hold the on/off key and the mode key at the same time.
4. Reinsert (1) AAA battery.
5. While still holding the on/off key, let go of ONLY the mode key.
6. Index over to the hand graphic on the LCD screen to edit. Use the up or down arrow key to choose 'SEL' or 'CLR'.

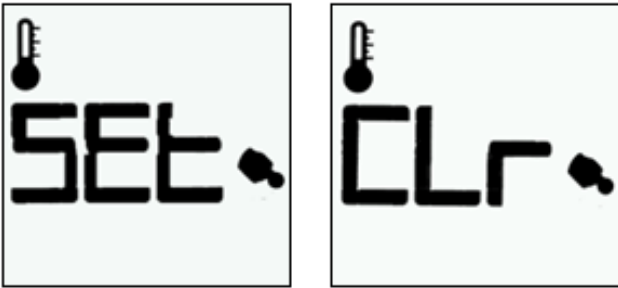

Figure 11.16 - Deactivate AUX

### 11.9.11 Remote Control Low Battery Detection

Remote control battery lifespan depends on various factors including battery quality, number of ignitions, changes to room thermostat set point, etc.

- When the remote control batteries are low, a battery icon will appear on the LCD display before all battery power is lost.
- When the batteries are replaced, this icon will disappear.



Figure 11.17 - Low Battery

# 12.0 Pressure Testing and Burner Adjustments

## 12.1 Pressure Testing

**NOTE:** The appliance and its appliance main gas valve must be disconnected from the gas supply piping system during any pressure testing of the system at test pressures in excess of 1/2 psi (3.5 kPa).

**IMPORTANT:** Pressure check taps for manifold (outgoing) and inlet (incoming) pressure have been incorporated into the valve. The pressure tap marked OUT measures outgoing pressure. The pressure tap marked IN measures incoming pressure.

### 12.1.1 Inlet Pressure Test

**NOTE:** Make sure to apply these incoming pressure test with all other gas appliances on, or at full capacity, in the house for proper pressure reading.

**IMPORTANT:** If the inlet pressure reading is too high or too low, contact the gas company. Only a qualified gas service technician should adjust incoming gas pressure.

1. Loosen the inlet (IN) pressure tap by turning screw counter-clockwise. See (A) in FIGURE 12.1.
2. Attach manometer using a 1/4" (6mm) I.D. hose.
3. Light pilot and burner. Check pressure to ensure it is between the minimum and maximum recommended pressure settings (TABLE 12.1).
4. Turn off burner and pilot.
5. Disconnect hose and tighten the inlet (IN) pressure tap by turning screw clockwise. Screw should be snug. Do not over tighten.
6. Relight pilot and burner. Then reattach manometer to the inlet pressure tap (A) to verify the tap is completely sealed. Manometer should read no pressure.

Fuel	Natural Gas	Propane
Gas Supply	Min - Max	Min - Max
Inlet Pressure Tap (A)	5" - 10.0" WC (1.25 - 2.49 kPa) 7" WC (1.74 kPa) recommended	11" - 13" WC (2.74 - 3.24 kPa)

Fuel	Natural Gas	Propane
Gas Supply	Low - High	Low - High
Inlet Pressure Tap (A)	1.6" - 3.5" WC (0.40 - 0.87 kPa)	6.4" - 10" WC (1.59 - 2.49 kPa)

### 12.1.2 Manifold Pressure Test

1. Light pilot.
2. Loosen manifold (OUT) pressure tap by turning screw counter-clockwise. See (B) in FIGURE 12.1.
3. Attach manometer to pressure tap using a 1/4" (6mm) I.D. hose.
4. Light burner. Check manometer reading. Refer to TABLE 12.2.
5. Turn burner and pilot off.
6. Disconnect manometer hose and tighten the manifold (OUT) pressure tap by turning screw clockwise. Screw should be snug. Do not over tighten.
7. Attach the manometer to the manifold pressure tap (B) to verify it is completely sealed. The manometer should read no pressure when pilot and burner are on.

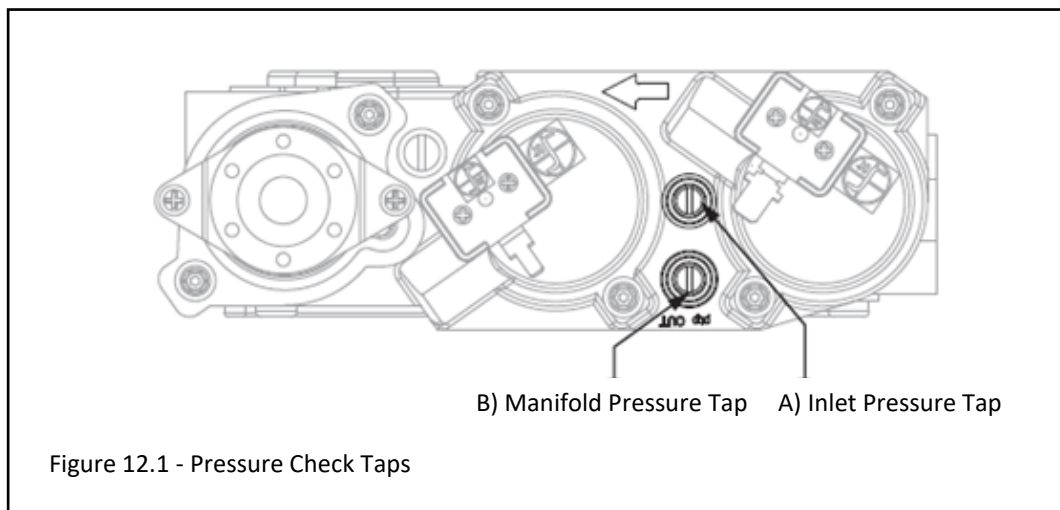



## 12.2 Flame Appearance Adjustment

**WARNING:** To avoid property damage or personal injury, allow the fireplace ample time to cool before making any adjustments.

Burner flame appearance and characteristics are affected by altitude, fuel quality, venting configuration, and other factors. After installation, this appliance may need additional adjustments to achieve optimum flame appearance and visual aesthetics.

### 12.2.1 Burner Venturis

**WARNING:** VENTURI ADJUSTMENT MUST BE DONE BY A QUALIFIED SERVICE TECHNICIAN.

**NOTE:** Burner venturi air shutter settings have been factory set. Refer to TABLE 12.3.

When this appliance is first lit, the burner flames will appear blue. During the first 15 minutes of operation, flame appearance will gradually turn to the desired yellow appearance. If the flames remain blue or become dark orange with evidence of sooting (black tips), adjustment of the air shutter opening may be necessary.

Regardless of venturi orientation, closing the air shutter will achieve a desired yellow flame, but may produce soot on the glass. Opening the air shutter will cause a short, blue flame that may lift off the burner.

### 12.2.2 Venturi Opening Adjustments

**IMPORTANT:** Slight adjustments to the venturi opening will create dramatic results. Adjust at slight increments until desired look is achieved. Refer to Table 12.4.

1. Remove the safety barrier, glass frame assembly, glass media, and lava rock (if installed). Remove media tray.
2. Loosen the screw on burner venturis and adjust as necessary. Re-tighten screws.
3. Reinstall all components previously removed.

<b>Fuel</b>	Natural Gas	Propane
<b>Left Burner</b>	1/8" (3mm)	1/2" (13mm)
<b>Center Burner</b>	1/8" (3mm)	1/2" (13mm)
<b>Right Burner</b>	1/8" (3mm)	1/2" (13mm)
<b>Bottom Burner</b>	1/8" (3mm)	3/8" (10mm)

<b>Flame Characteristics</b>	<b>Cause</b>	<b>Solution</b>
Dark, orange flame with black tips	Venturi closed too far	Open venturi slightly
Short, blue flames	Venturi open too far	Close setting slightly
Lifting (ghosting) flames	Gas pressure too high and/or venturi closed too far	Check manometer settings and/or open venturi setting slightly

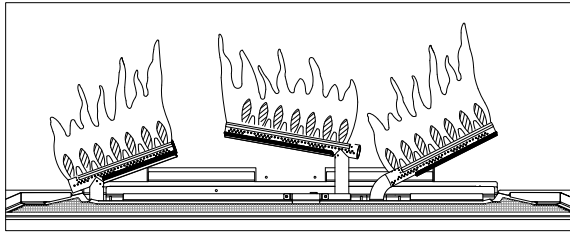
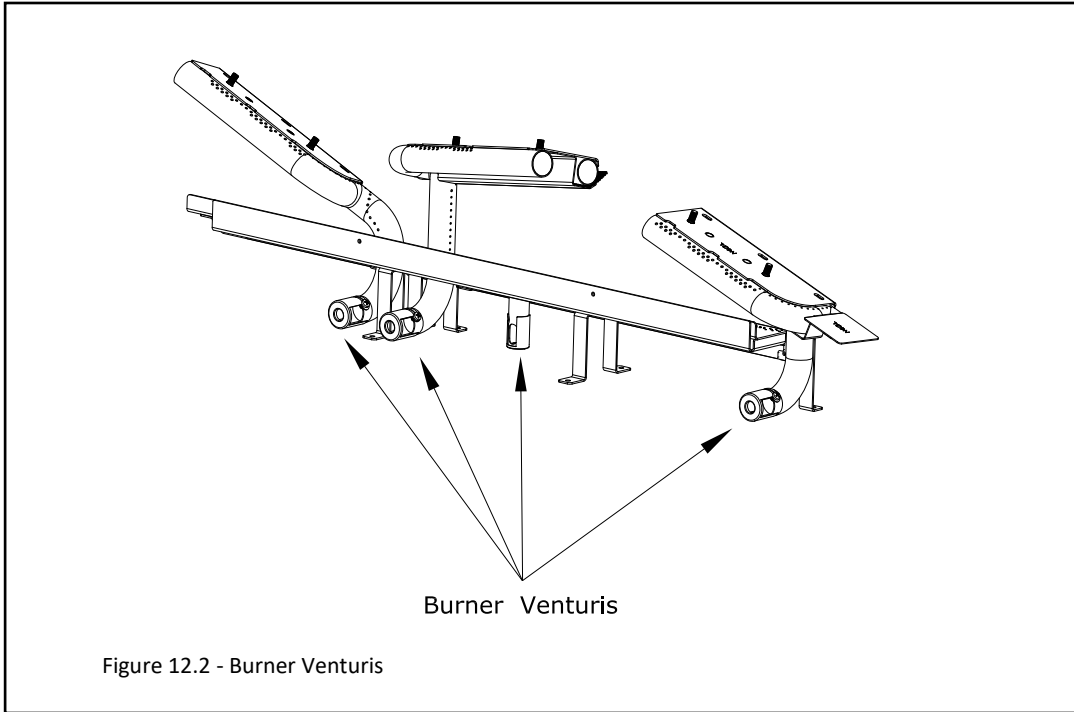

Lazy, yellow flames-no adjustment necessary  
(Ideal Flame Appearance)

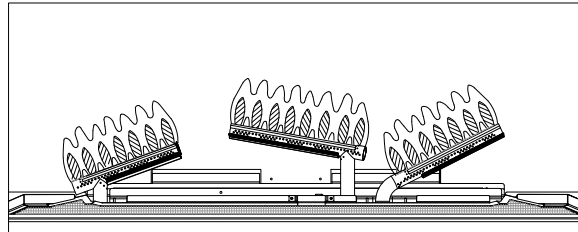

Short, blue flames  
(Venturi open too far. Close venturi slightly)

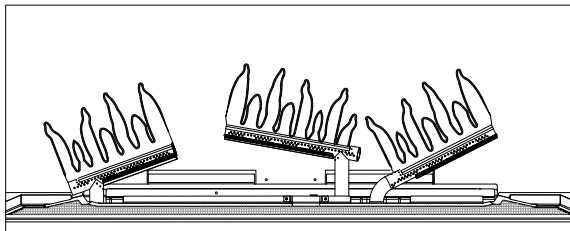

Dark, orange flames with black tips  
(Venturi closed too far. Open venturi slightly)

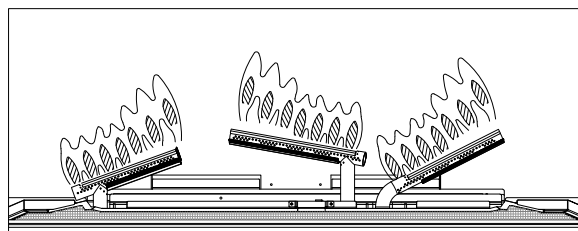

Lifting (ghosting) flames  
(Venturi closed too far. Open venturi slightly)  
OR  
(Gas pressure too high-check with manometer)

Figure 12.3 - Flame Appearance and Characteristics

### 12.2.3 Vent Restriction (after installation)

**WARNING:** To avoid property damage or personal injury, allow the fireplace ample time to cool before making any adjustments.

**WARNING:** Improper vent installation may cause the burner flames to lift or “ghost.” Perform a visual check on flame appearance after restriction adjustment to ensure proper performance.

Vertical terminations may display an active, compact flame. If this appearance is not desirable, a restrictor plate may need to be installed or modified after vent termination installation. Access to the vent exit for restriction can be reached through the fireplace baffle. See Figure 12.4

Refer to TABLE 12.4 and FIGURE 12.3 for flame appearance adjustments. Allow the fireplace to burn for 15 minutes before making any adjustments.

#### Restrictor Plate Installation

1. Remove the safety barrier and glass frame assembly.
2. Bend the tabs on the restrictor (included in fireplace components packet) to approximately 80° angles. This will create tension when the restrictor is inserted into the exhaust pipe.
3. Insert restrictor into the 5" (127mm) exhaust pipe with the tabs pointing towards you.
4. Reinstall the fireplace baffle with (4) screws previously removed.
5. Reinstall all components previously removed.

Flame Appearance	Draft Problem	Solution
Short, flickering	Excessive draft and/or not enough restriction	Add restrictor plate
Lifting or ghosting	Insufficient draft	Remove inner ring(s) on restrictor plate or remove restrictor plate
*If flames continue to lift or ghost after opening the restrictor plate and verifying correct vent installation, shut off the gas supply and call a qualified service technician.		

#### Restrictor Plate Modification

1. Remove the safety barrier and glass frame assembly.
2. Remove the restrictor from the 5" (127mm) exhaust pipe by pulling the restrictor down and out.
3. Make necessary modifications to achieve desired flame appearance.
4. Insert restrictor into the 5" (127mm) exhaust pipe with the tabs pointing towards you.
5. Reinstall the fireplace baffle with (4) screws previously removed.
6. Reinstall all components previously removed.

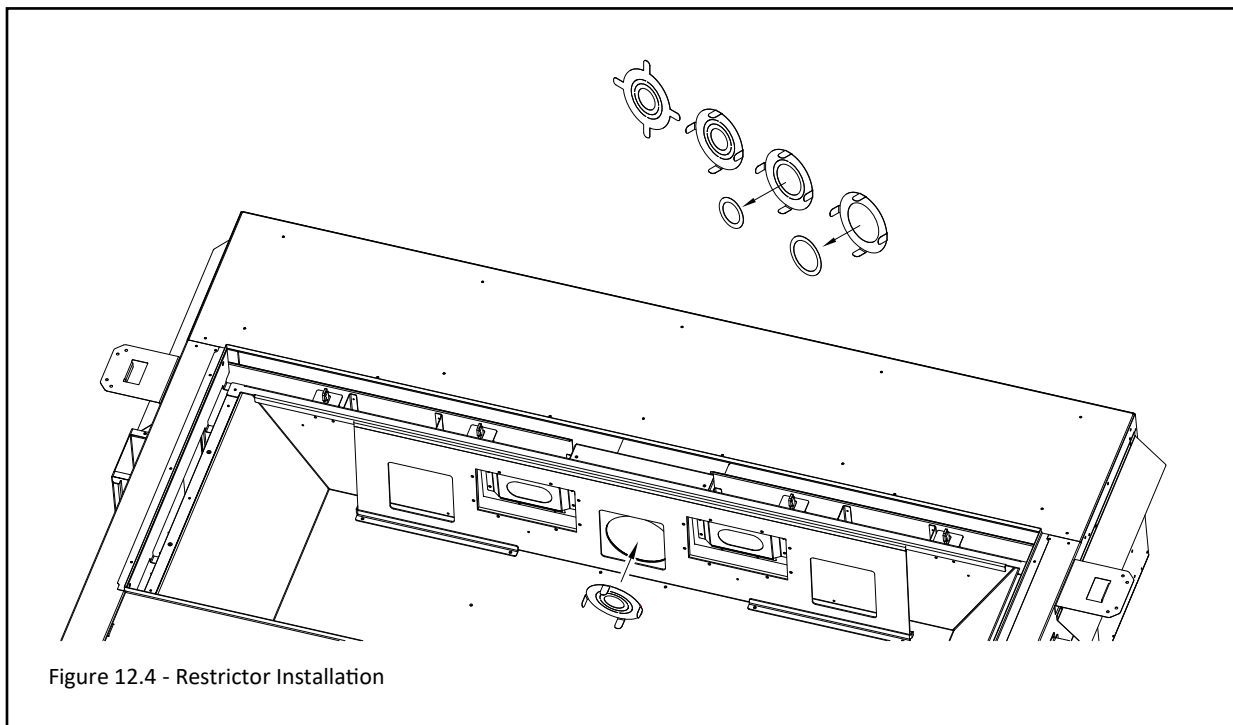

Figure 12.4 - Restrictor Installation

# 13.0 Troubleshooting

ATTENTION: Troubleshooting must be performed by a qualified technician.

Before proceeding with the steps in the following troubleshooting guide,

- Verify proper 120VAC power supply to the control module.
- Verify the control module back-up battery pack and the remote control batteries are fresh and installed with correct polarity.
- Verify all connections between the wire harnesses and the system components are proper and positive.
- Verify inlet pressure meets the recommended inlet pressure. If necessary, adjust line pressure regulator.
- Verify the communication link is established between the remote control and the IFC module.
- CAUTION: Label all wires prior to disconnection when servicing controls. Wiring errors can cause improper and dangerous operation.
- Verify proper operation after servicing.

Issue	Cause	Solution
<b>Pilot will not light</b>	Electrical power interrupted or disconnected	Restore electrical power to appliance or use battery back-up
	Wiring disconnection	Ensure batteries are fully charged if using battery back-up as power source.  Use wiring schematic in this manual to determine that all wiring connections are secure and correct.
	Gas supply turned off	Check remote shut-off valves from the appliance. Usually there is a valve near the main gas line. There may be more than (1) valve between the appliance and main gas line.
<b>Pilot will not stay lit</b>	No propane in tank	Check propane tank. Refill if necessary.
	Low gas pressure	Consult a plumber or gas supplier  Can be caused by situation such as a bent line, too narrow diameter or pipe, or a low line pressure
	Pilot adjustment screw not sealed	Seal pilot adjustment screw. Do not over-tighten.
	Pilot flame not making contact with the flame rectification sensor on the pilot assembly	Verify the pilot envelopes the top of the flame sensor and extends far enough onto the burner for ignition
<b>Pilot flame always on, or will not extinguish</b>	Control system set to CPI mode.	Set control system to IPI mode.

Issue	Cause	Solution
<b>Burner flame will not light</b>	ON/OFF rocker switch in OFF position	Switch rocker switch to ON position.
	Gas supply turned off	Check for multiple shut-offs in the supply line. Verify gas supply is turned on.
	Low gas supply	Consult with plumber or gas supplier. Check propane tank. Refill if necessary.
	Wiring disconnection or improper wiring	Check for faulty or incorrect wiring. Refer to FIGURE 10.1, Electrical Diagram.
	Plugged burner orifice	Remove blockage.
	Pilot flame	Verify the pilot flame is properly directed to ignite burner. See pilot flame troubleshooting in this section.
	Remote control not working	Replace Batteries.
	No call for heat	Verify remote control is powered ON and thermostat operation is turned OFF.
<b>Pilot and burner extinguish while in operation</b>	No propane in tank	Check propane tank, Refill if necessary.
	Incorrect glass assembly installation	Refer to section 9.1, GLASS ASSEMBLY.
	Incorrect vent cap installation	Adjust if necessary.
	Vent cap blockage	Remove debris if necessary.
	Improper pitch on horizontal venting	1/4" (6mm) rise for ever 12" (305mm) of travel is required on horizontal venting.
	Exhaust vent pipe leaking exhaust gases back into firebox	Check for leaks and repair if necessary.
	Excessive draft	A restrictor may need to be installed or modified. Refer to section 12.2.3 Vent Restriction.
<b>Soot appears on glass</b>	Improper log placement	Refer to section 9.4, LOG SET INSTALLATION.
	Improper venturi settings	Venturi air shutters may need to be opened slightly to allow more air into the gas mix. Refer to section 12.2.1, BURNER VENTURIS.
	Incorrect vent cap installation	Adjust if necessary.
	Vent cap blockage	Remove debris if necessary.

Issue	Cause	Solution
<b>Flame burns blue and lifts off burner</b>	Improper venturi setting	The venturi air shutter may need to be close slightly to allow less air into the gas mix. Refer to section 12.2.1, BURNER VENTURIS.
	Incorrect vent cap installation	Adjust if necessary.
	Blockage or leakage of the vent system	Check the vent pipes for leaks and the vent cap for debris. Repair the vent pipes or remove debris from vent cap, if necessary.
<b>No reaction to command</b>	Battery backup batteries or remote control batteries low	Replace the batteries.
	No communication between remote control and control module	Reprogram remote control to IFC module
	A maximum number of failed ignitions or flame restorations has been reached.	Reset IFC module

# 14.0 Maintenance

**ATTENTION:** Installation and repair should only be done by a qualified service person. The appliance should be inspected before use and at least annually by a professional service person. More frequent cleaning might be required due to excessive lint from carpeting, bedding material, et cetera. It is imperative that control compartments, burners, and circulating air passageways of the appliance be kept clean. Use a vacuum to clean all components.

**WARNING:** The appliance area must be kept clear and free from combustible materials, gasoline and other flammable vapors and liquids.

## 14.1 Firebox

**Performed by:** Qualified Service Person

**Frequency:** Annually

**Action:**

- Vacuum and clean any debris in the firebox that is not supposed to be there.
- Inspect and operate the bottom and top latch assembly. Verify the assembly is free from obstruction to operate. The handles must have spring tension but be able to move forward freely

## 14.2 Fan

**CAUTION:** Label all wires prior to disconnection when servicing controls. Wiring errors can cause improper and dangerous operation. Verify proper operation after servicing.

**Performed by:** Qualified Service Person

**Frequency:** Annually

**Action:**

- Disconnect the fan from electrical current and vacuum.
- The bearings are sealed and require no oiling.

### 14.2.1 Fan Kit Removal

1. Disconnect electrical power.
2. Remove the safety barrier screen and component access tray.
3. Disconnect the fan kit wiring from the control module.
4. Rotate and tilt the fan kit up to remove the fan from the air channel.
5. Remove the fan kit and service.
6. Reinstall in reverse order. Reinstall all previously removed components

## 14.3 Vent System

**NOTE:** If the vent-air intake system is disassembled for any reason, reinstall per instructions provided with installation. If installing Kozy Power Vent (#KPV), please reference the manual included with the kit. For natural draft vent installation, refer to section 8.0, VENTING.

**Performed by:** Qualified Service Person

**Frequency:** Annually

**Action:**

- Examination of the vent system is required.
- Inspect the condition of vent and vent terminal for sooting or obstruction and correct if present.
- The flow of combustion and ventilation air must not be obstructed.

## 14.4 Glass Assembly

**CAUTION:** Do not operate appliance with the glass assembly removed, cracked, or broken. Use protective gloves to handle any broken or damaged glass assembly components.

**WARNING:** Do not use substitute materials.

**WARNING:** Avoid striking or slamming glass assembly. Avoid abrasive cleaner. DO NOT clean glass while it is hot.

**IMPORTANT:** Any safety screen, guard, or barrier removed for servicing the appliance must be replaced prior to operating the appliance.

**Performed by:** Homeowner

**Frequency:** Annually

**Action:**

- Prepare a work area large enough to accommodate the glass assembly on a flat, stable surface.
- Remove safety screen and glass frame assembly.
- Clean glass window with a suitable fireplace glass cleaner using a soft cloth. Abrasive cleaners must not be used. Be careful not to scratch the glass when cleaning.
- Reinstall glass assembly and safety screen. Do not operate fireplace without safety screen.

**Performed by:** Qualified Service Person

**Frequency:** Annually

**Action:**

- Clean glass window with a suitable fireplace glass cleaner using a soft cloth. Abrasive cleaners must not be used. Be careful not to scratch the glass when cleaning.
- Inspect the glass for cracks, scratches, and nicks.
- Verify the glass assembly is properly intact and not damaged.
- Replace the glass and the assembly #701-066T as necessary.
- Only Hussong Mfg. Co., Inc. will supply the replacement of glass assembly as a complete unit.

The glass assembly and the spring loaded latches act as the pressure relief mechanism.

**Performed by:** Qualified Service Person

**Frequency:** Annually

**Action:**

- Follow the steps above to verify the glass assembly.
- Verify that the spring loaded latches move freely as outlined in 14.1.

## 14.5 Burner and Pilot System

The burner assembly may be removed for easier access to the control compartment. **See Section 9.5 Control Board Removal and Installation** for instructions. **See Section 12.2 Flame Appearance Adjustment** for information on adjusting burner appearance.

Verify gas supply is turned on and filled. Consult with plumber or gas supplier as necessary.

**Performed by:** Qualified Service Person

**Frequency:** Annually

**Action:**

- Vacuum all components of the burner system.
- Check all accessible gas-carrying tubes, connections, pipes and other components for leaks.
- Inspect the operation of the flame safety system Pilot or Flame rectification device. Visually check pilot light when in operation.
- Inspect and ensure the lighting of the main burner occurs within (4) seconds of the main gas valve opening. Check for faulty or incorrect wiring and correct or replace as necessary. Inspect primary air openings (burner ports) for blockage, especially near the pilot.
- Visually check burner flame pattern when in operation. Flames should be steady, not lifting or floating.
- Test and measure the flame failure response time of the flame safety system. It must de-energize the safety shutoff in no more than (30) seconds.

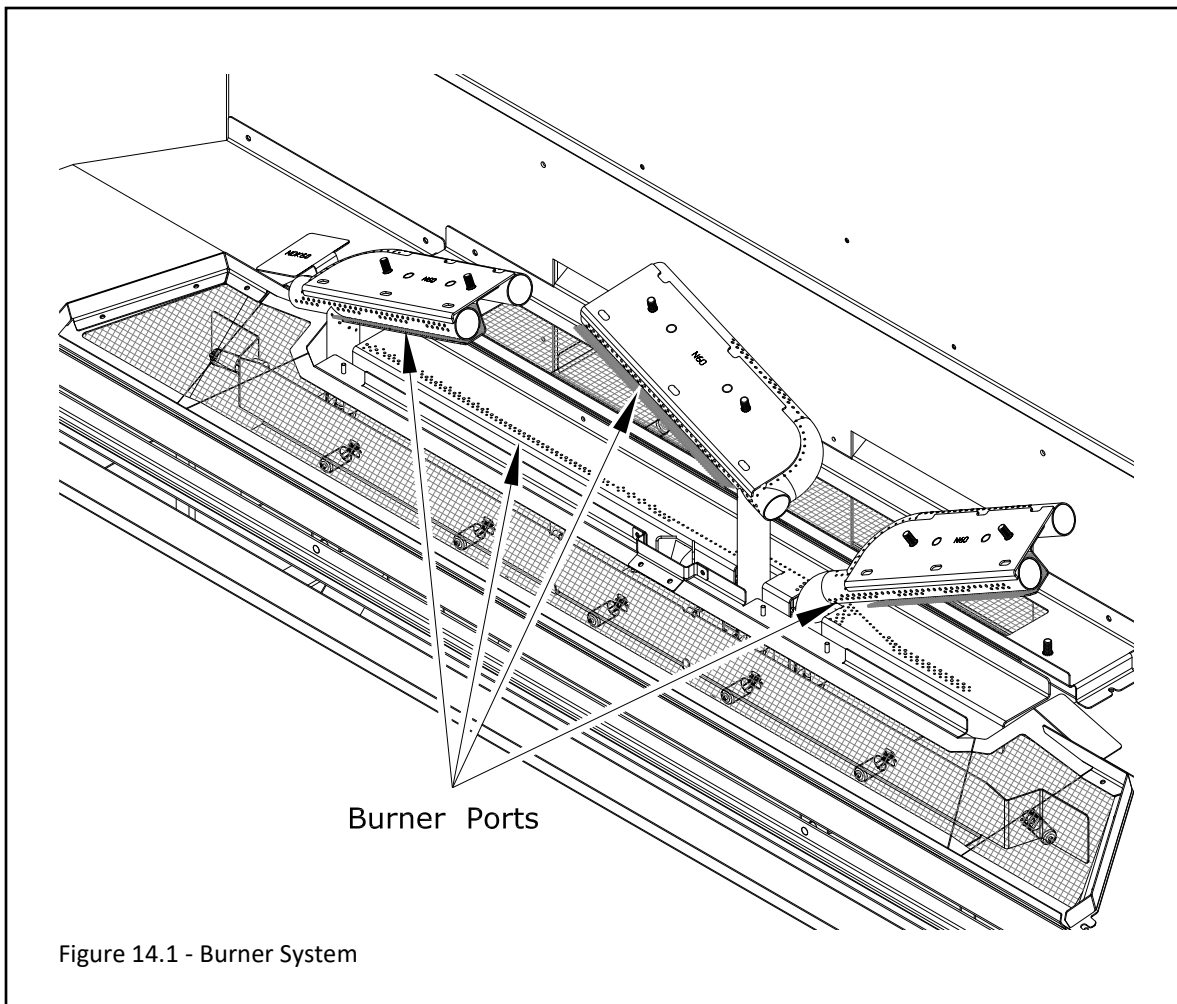



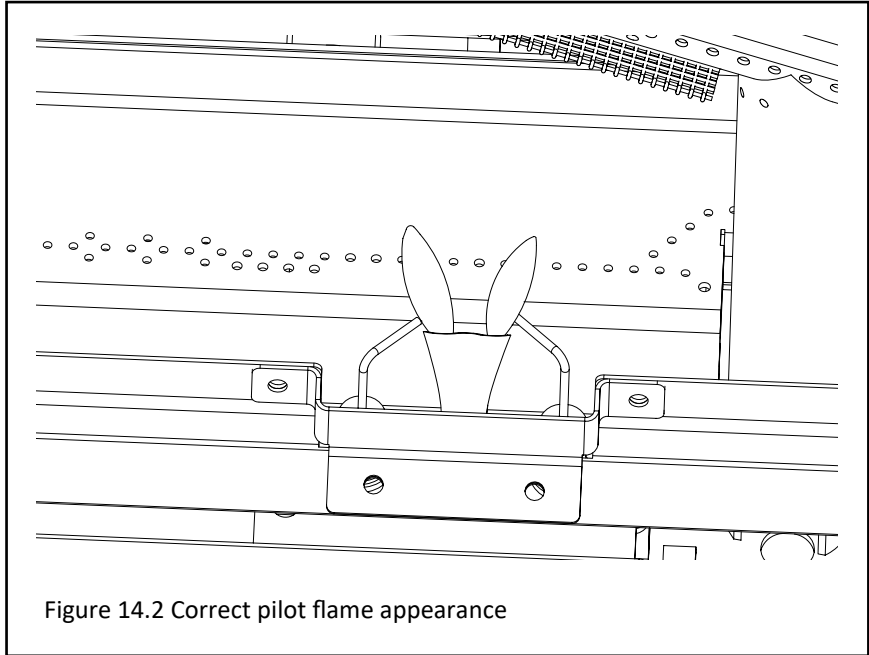
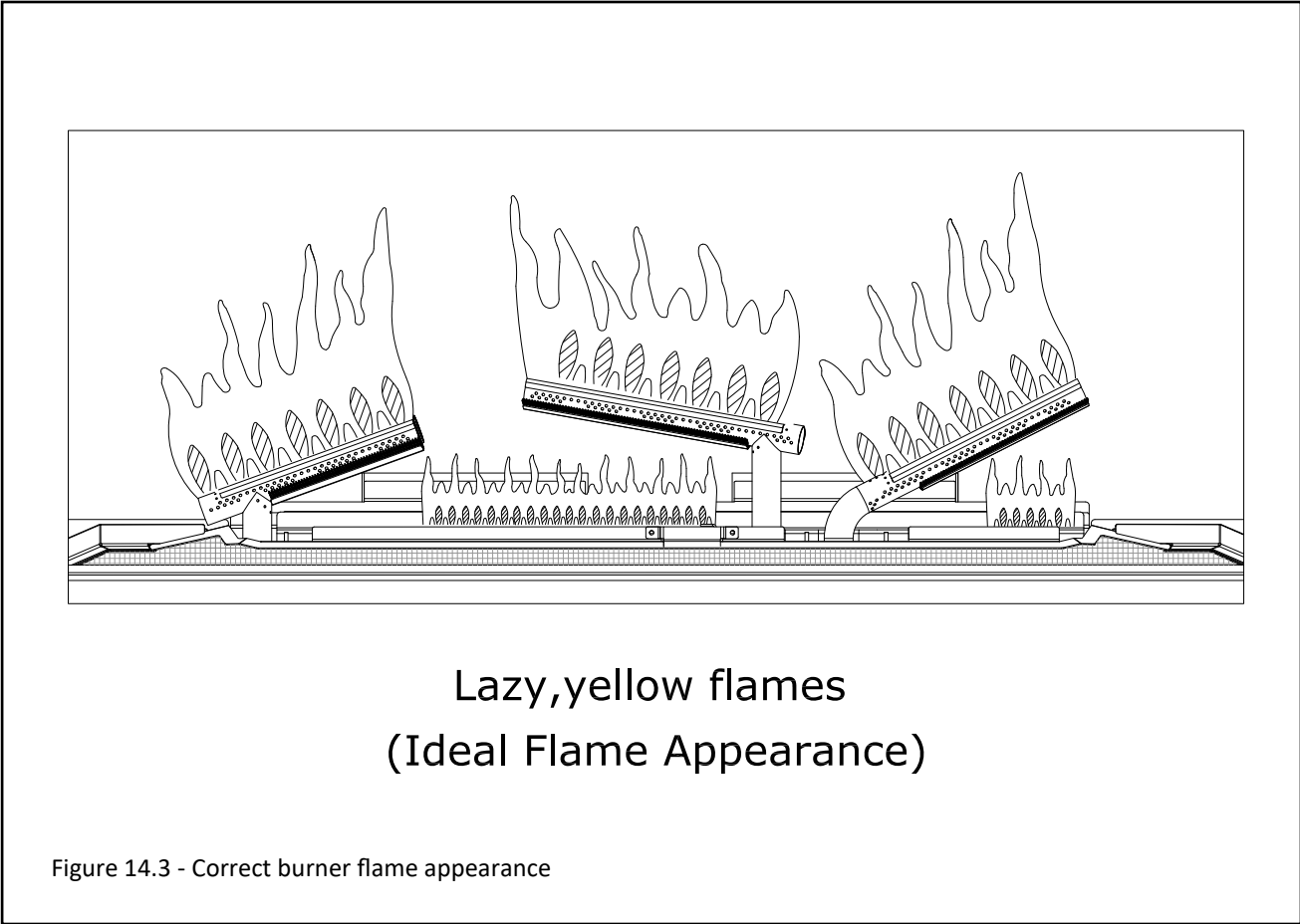

Figure 14.2 Correct pilot flame appearance



Lazy, yellow flames  
(Ideal Flame Appearance)

Figure 14.3 - Correct burner flame appearance

# 15.0 Replacement Parts List



HUSSONG MANUFACTURING CO., INC.

P.O. BOX 557 204 INDUSTRIAL PARK DRIVE  
LAKEFIELD, MINNESOTA USA 56150-0577

Replacement parts are available through your local dealer. Contact your local dealer for availability and pricing. The following warning is for replacement parts for this appliance.

**⚠ WARNING:** This product can expose you to chemicals including Lead, which is [are] known to the State of California to cause cancer, birth defects or other reproductive harm. For more information, visit

[www.P65Warnings.ca.gov](http://www.P65Warnings.ca.gov).

Control Board and Parts			
S.I.T. Complete Board Assembly - Natural Gas	NK60TL-130		S.I.T. Transmitter (Remote Control) 700-408
S.I.T. Complete Board Assembly - Propane	NK60TL-131		Burner Orifice - #48 (Left, Center, and Right) - Natural Gas 700-248
S.I.T. IPI Gas Valve - Natural Gas	700-660		Burner Orifice - #54 (Bottom) - Natural Gas 700-254
S.I.T. IPI Gas Valve - Propane	700-660-1		Burner Orifice - #1.10mm (Left, Center, and Right) - Propane 700-110M
Main Power Wire Harness	700-350A		Burner Orifice - #65 (Bottom) - Propane 700-265
Proflame 2 IFC Module	700-652		Left Burner Assembly NK60TL-350
IFC Wire Harness Assembly	700-653		Right Burner Assembly NK60TL-351
Fan / Light Kit Wire Harness	700-657		Center Burner Assembly NK60TL-352
ON/OFF Wire Harness	700-656		Bottom Burner Assembly NK60TL-035
Ember Bed AUX Harness	800-AUX		Left Burner Rockwool Screen NK60TL-350S
IPI Pilot Assembly - Natural Gas	900-064A		Right Burner Rockwool Screen NK60TL-351S
IPI Pilot Assembly - Propane	900-064-1		Center Burner Rockwool Screen NK60TL-352S
Pilot Orifice - Natural Gas - #.023NG	700-123		36" Black 3/8" Gas Line (into valve) 700-383
Pilot Orifice - Propane - #.014LP	700-114		18" Black Flex Tube 700-213B
PSE Conversion Kit - Natural Gas	NCK-NK60TL-P30		7" Flare x Brazed Fitting 700-223F
PSE Conversion Kit - Propane	LCK-NK60TL-P30		18" Flex Tube 700-225F
Natural Gas - Valve Stepper Motor	700-503		12-1/2" Flare x Brazed Fitting 700-226F
Propane - Valve Stepper Motor	700-503-1		15" Flare x Brazed Fitting 700-227F

<b>Glass and Glass Parts</b>	
Glass with Gasket - 61-3/4" x 22-1/8"	701-066T
1 1/8" Glass Gasket with Adhesive	900-007
Replacement Valance	NK60TL-005
Glass Latch Tool	JOR-GLT

<b>Safety Barriers</b>	
Safety Screen Barrier	NK60TL-ES

<b>Surround</b>	
Rectangle Surround	NK60TL-RS

<b>Fan Kit</b>	
Fan Kit	SL42-028

<b>Additional Components</b>	
5" (127mm) Restrictor Plate	900-086
Manual 3/8" Gas Shut-off Valve	700-380
Vent Heat Shield Assembly	NK60TL-HHS
Component Access Cover	NK60TL-027AC

<b>Light Kits</b>	
20W Halogen Bulb	600-676
Light Kit - Ember Bed	NK60TL-LKT
Light Kit - Top	600-TLK
1.5lb. (0.68kg) Ember Bed Crushed Glass *	600-697
*9 lbs. used across fireplace - Order up to (6) bags of 1.5 lbs. to replace glass	

<b>Log Set Replacement Parts</b>		
14 Piece Log Set	NK60TL-500	NK60TL-B501
Log #1	TL60-1	TL60-B1
Log #2	TL60-2	TL60-B2
Log #3	TL60-3	TL60-B3
Log #4	TL60-4	TL60-B4
Log #5	TL60-5	TL60-B5
Log #6	TL60-6	TL60-B6
Log #7	TL60-7	TL60-B7
Log #8	TL60-8	TL60-B8
Log #9	TL60-9	TL60-B9
Log #10	TL60-10	TL60-B10
Log #11	TL60-11	TL60-B11
Log #12	TL60-12	TL60-B12
Log #13	TL60-13	TL60-B13
Log #14	TL60-14	TL60-B14

# Limited Lifetime Warranty

---

## Warranty Coverage

Hussong Manufacturing Company, Inc. (Hussong Mfg.) warrants this Kozy Heat gas appliance from the date of purchase to the original purchaser, that it is free of defects in materials and workmanship at the time of manufacture. Registering your fireplace warranty does not require any documents to be sent in to Hussong Mfg. Please retain your proof of purchase reflecting the date of purchase along with the serial number and model of your fireplace for any future warranty claims.

If a defect is noted within the warranty period, the customer should contact their authorized dealer for service within 30 days.

### 30 Days: Parts & Labor\*

- Paint
- Light bulbs
- Gasket material
- Glass media and media dam

### Year 1: Parts & Labor\*

All parts and material except the items listed in the 30 day warranty and any exclusions or limitations that may apply

***\*Hussong Mfg. will issue labor reimbursement to an authorized dealer only. Hussong Mfg. will not be liable for charges occurred as a result of any service performed by a non-authorized service provider, without pre-authorization.***

### Years 2 through Lifetime: Parts Only

- Firebox
- Heat Exchanger
- Logs
- Burner tube or pan
- Outer shell
- Heat shield(s)
- Front Viewing Glass (thermal shock only)
- Refractory Firebox liner (excluding enamel and glass panels)

## EXCLUSIONS AND LIMITATIONS

1. This appliance must be installed by a licensed, authorized service technician or contractor. It must be installed, operated and maintained at all times in accordance with the instructions in the owner's manual or the warranty is void.
2. This warranty is nontransferable and is made to the original purchaser only.
3. This warranty excludes standard wear and tear of the appliance which is considered normal usage over time.
4. Discoloration and some minor expansion, contraction or movement of certain parts, resulting in noise, is normal and not a defect.
5. Warranty is automatically voided if the appliance's serial number and/or testing label is removed or if the appliance is altered or tampered with in any way.
6. Warranty is void if the appliance is subject to submersion in water or prolonged periods of dampness or condensation. Any damage to any part of the appliance due to water or weather damage which is the result of, but not limited to, improper chimney/venting installation will also render this warranty void.
7. This warranty does not cover installation and operational related problems such as environmental conditions, nearby trees, buildings, hilltops, mountains, inadequate venting or ventilation, excessive offsets, negative air pressures caused by any mechanical systems.
8. Chimney components and other Non-Hussong Mfg. accessories used in conjunction with the installation of this appliance are not covered under this warranty.
9. Damage to plated surfaces or accessories, if applicable, caused by scratches, fingerprints, melted items or other external sources left on the surfaces from the use of cleaners is not covered under this warranty.

# Limited Lifetime Warranty

---

## EXCLUSIONS AND LIMITATIONS (continued)

10. It is expressly agreed and understood that this warranty is Hussong Mfg.'s sole obligation and purchaser's exclusive remedy for defective fireplace equipment. Hussong Mfg. is free of liability for any damages caused by this appliance, as well as inconvenience expenses and materials. Incidental or consequential damages are not covered by this warranty. In some states, the exclusion of incidental or consequential damage may not apply. Hussong Mfg. shall not be held to implied warranties and this warranty shall replace all previous warranties.
11. This limited lifetime warranty is the only warranty supplied by Hussong Mfg. Any warranties extended to the purchaser by the dealer/distributor, whether expressed or implied, are hereby disclaimed and the purchaser's recourse is expressly limited to the warranties set forth herein.
12. Any part repaired or replaced during the limited warranty period will be warranted under the terms of the limited warranty for a period not to exceed the remaining term of the original limited warranty.
13. Any replacement part repaired after the warranty period will include a 90 day parts coverage
14. Hussong Mfg. may require the defective part to be returned using a pre-authorized RGA number or a photo of the defective component. Failure to provide either can result in a denied claim.
15. This warranty does not cover the appliances ability to heat a desired space, as there are many factors that can impact the heating performance in each home. Consideration should be implied to the appliance's location, room size, home design, environmental conditions, insulation, and tightness of the home.
16. Hussong Mfg. reserves the right to make changes at any time, without notice, in design, material, specifications, and prices. Hussong Mfg. reserves the right to discontinue models and products.

*July 2018*

